

NOTES:

- MATERIALS AND FINISHES (PLATING THICKNESS IN MICROINCHES):
 - BODY ASSEMBLY - BRASS, GOLD PLATING (50 MIN THICK)
 - CAP - BRASS, GOLD PLATING (50 MIN THICK)
 - LOOSE CONTACT & ASSEMBLED CONTACT - BeCu, GOLD PLATING (50 MIN THICK)
 - GASKET - SILICONE RUBBER
 - RETAINGING RING - BeCu
 - COUPLING NUT - BeCu, GOLD PLATING (50 MIN THICK)
 - OUTER FERRULE - COPPER, GOLD PLATING (50 MIN THICK)
 - HEAT SHRINK TUBING - POLYOLEFIN
 - ASSEMBLED CONTACT - BRASS, GOLD PLATING (50 MIN THICK)
 - INSULATORS - PTFE

- ELECTRICAL:
 - A. IMPEDANCE: 50 OHM
- MECHANICAL:
 - A. DURABILITY: 500 CYCLES MIN.
 - B. TEMPERATURE RANGE: -65° C TO +165° C

- PACKAGING:
 - A. QUANTITY: SINGLE PACK
 - B. MARKING: BAG TO BE MARKED "AMPHENOL, 901-148-15, AND DATE CODE"

- CABLE ASSEMBLY INSTRUCTIONS
 - A. TRIM CABLE AS SHOWN.
 - B. SOLDER CABLE CENTER CONDUCTOR TO CONTACT.
 - C. INSERT CABLE WITH PTFE INSULATOR ENTERING CONNECTOR AND BRAID OVER KNURL.
 - D. CRIMP FERRULE WITH AMPHENOL TOOL 227-944 AND DIE SET 227-1221-57 CLOSURE 'A', .213" HEX DIE. USE M22520/1-15 POSITIONER.

6 SHOWS CABLE ENTRY DIMENSIONS.

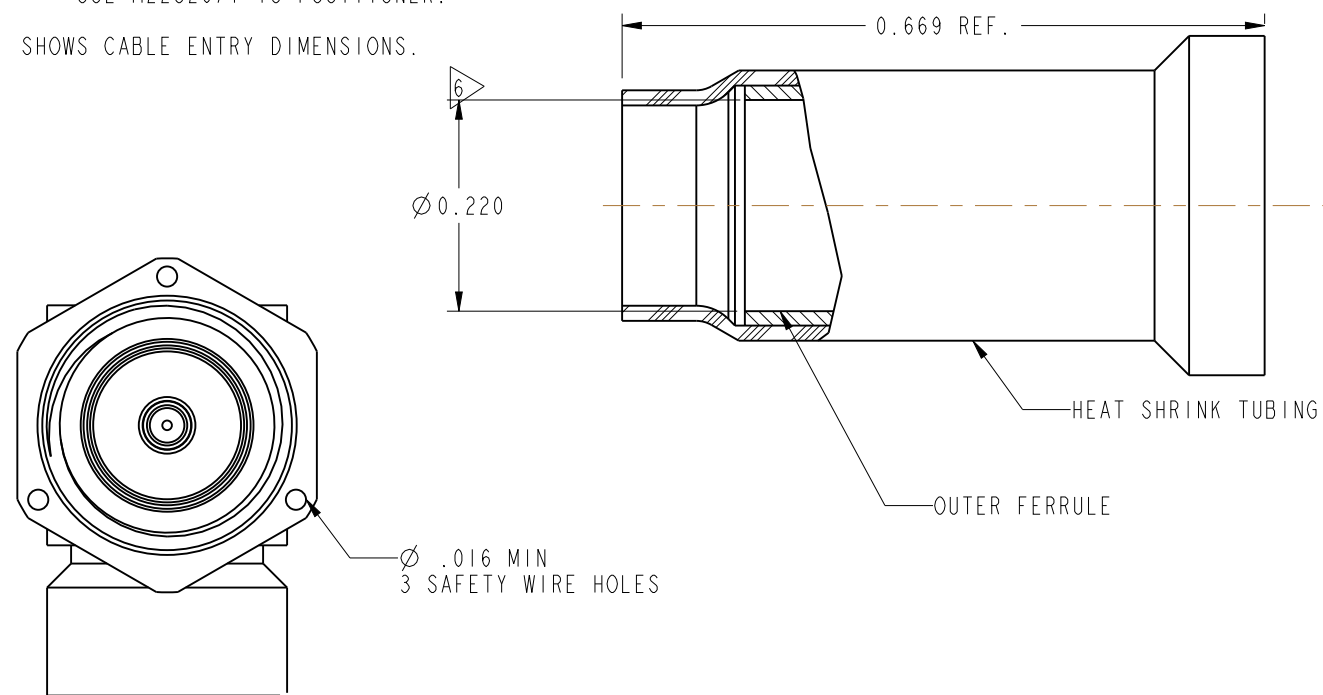

THIRD ANGLE PROJ.

REVISIONS

REV	DESCRIPTION	DATE	ECO	APPR
--	OFFICIAL ENG. RELEASE TO MFG.	-----	-----	
AA	REDRAWN IN PRO E & ADDED COD	9/20/13	49679	KR
AB	ADDED VIEW FOR WIRE HOLES	3/19/14	49912	CPM

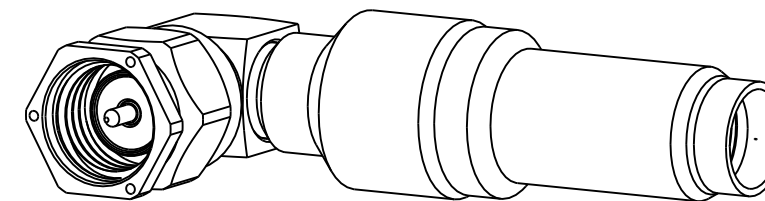

SCALE 2.500

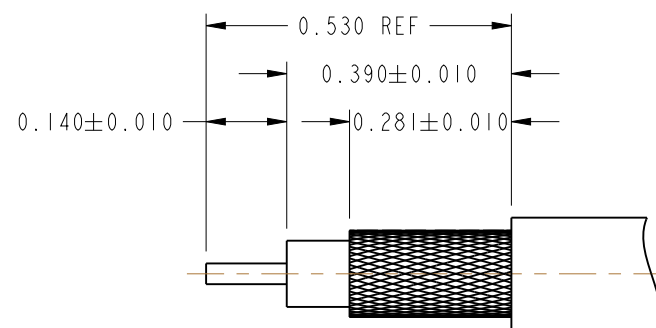

RECOMMENDED CABLE STRIPPING DIMENSIONS

MIL-C-39012 INSPECTION

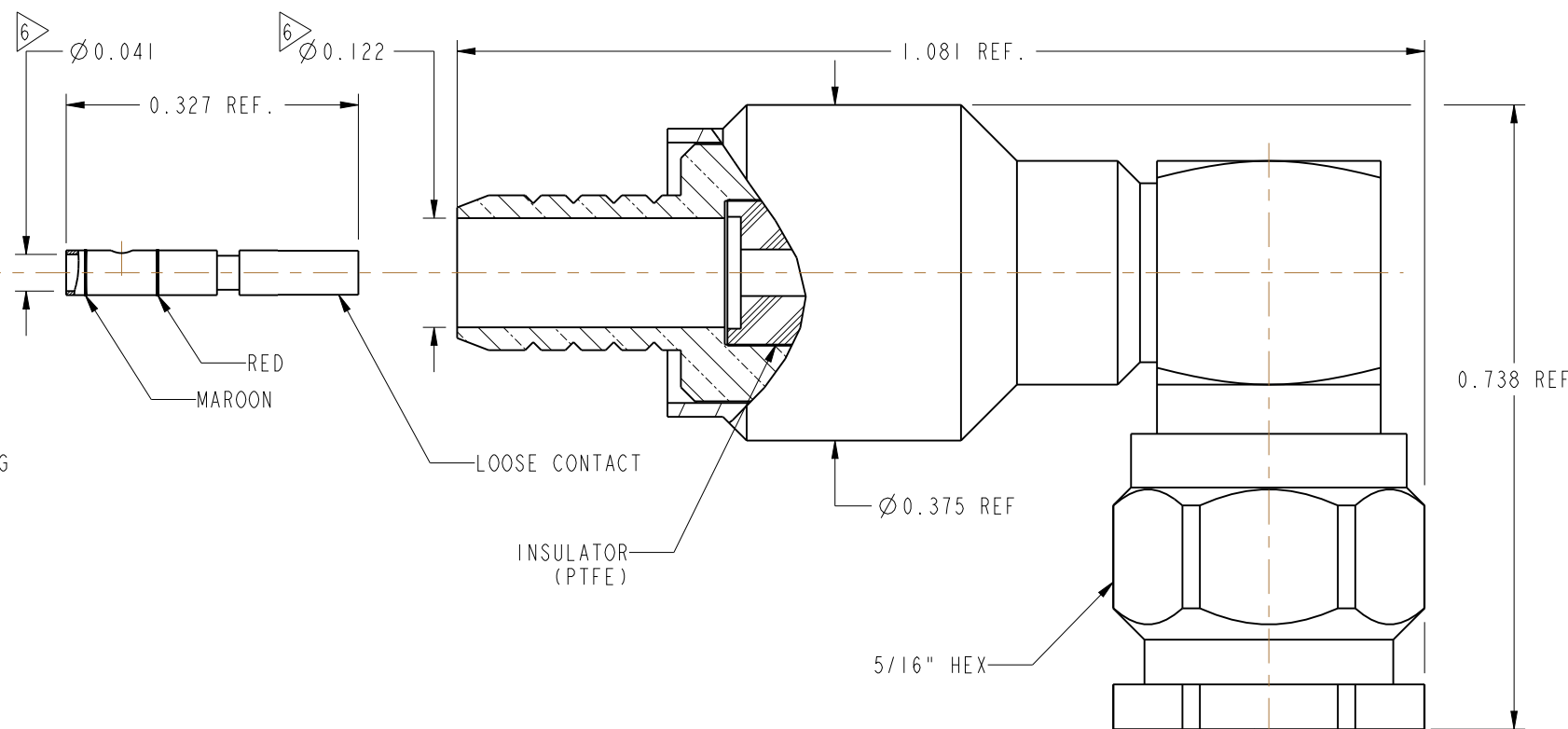

CUSTOMER OUTLINE DRAWING

ALL OTHER SHEETS ARE FOR INTERNAL USE ONLY

INTERFACE PER MIL-STD-348 SMA SERIES

THIS CONNECTOR IS COVERED BY U.S. PATENT 3,439,294.

UNLESS OTHERWISE SPECIFIED, DIMENSIONS ARE IN INCHES AND TOLERANCES ARE: 2 PLACE DECIMAL 3 PLACE DECIMAL ANGLES ±.015 (0,381 mm) ±.005 (0,127 mm) ± 1°	MATERIAL	DRAWN	DATE	TITLE SMA 90° PLUG CRIMP TYPE FOR RG-400/U & 142/U CABLE		Amphenol RF www.amphenolrf.com
	SEE NOTES	KARTHIK R	12-Aug-13			
NOTICE - These drawings, specifications, or other data (1) are, and remain the property of Amphenol corp. (2) must be returned upon request; and (3) are confidential and not to be disclosed to any person other than those to whom they are given by Amphenol Corp. the furnishing of these drawings, specifications, or other data by Amphenol Corp., or to any other person to anyone for any purpose is not to be regarded by implication or otherwise in any manner licensing, granting rights to permitting such holder or any other person to manufacture, use or sell any product, process or design, patented or otherwise, that may in any way be related to or disclosed by said drawings, specifications, or other data.	REFERENCE	ENGINEER	DATE	SCALE: 5.0:1.0 SHEET 2 OF 2		DRAWING NO.901-148-15
	DOR 312191-51 M39012/56-4502	ABR	09-Jul-80	DWG SIZE B		ITEM NO.901-148-15
	FINISH	APPROVED	DATE	REV	PART NO.901-148-15	
		K. CAPOZZI	9/20/13	AB		