



MAX24288 EV KIT

Evaluates: MAX24288

General Description

The MAX24288 EV Kit is an easy-to-use evaluation kit for the MAX24288 IEEE 1588 Packet Timestamper and Clock. On the network side of the MAX24288 an SFP module cage supports either a 1000BASE-X optical module or a module containing a 10/100/1000Mbps Ethernet PHY with an SGMII system interface. On the system side of the MAX24288 an unmanaged switch IC with integrated PHYs plus magnetics and RJ-45 jacks provides an easy Cat 5 Ethernet connection to 1588 test equipment or a processor board running 1588 software.

An on-board high-stability TC-OCXO oscillator is provided to allow evaluation of 1588 performance with a variety of network PDV and impairment scenarios. Also, the board can accept an external oscillator input for testing alternate oscillators. The board provides SMB connectors for three device GPIO signals. Through these connectors clock and 1PPS signals can be input or output to lock the MAX24288 time clock to a master time clock or to lock other 1588 components to the MAX24288.

Typically the board is controlled by EV kit software running on a Windows PC through the USB interface. The board also has SPI and JTAG headers through which the MAX24288 can be controlled by a processor on another board as needed.

Demo Kit Contents

- ◆ MAX24288 Board
- ◆ Power Supply
- ◆ USB Cable

[Ordering Information](#) appears at end of data sheet.

Features

- ◆ Network-Side SFP Cage Accepts Optical or Electrical Ethernet SFP modules
- ◆ System-Side Unmanaged Ethernet Switch for Easy Connection to Processor Running 1588 Software.
- ◆ GPIO SMB Connectors to Input or Output Clock Signals and 1PPS Signals
- ◆ Onboard TC-OCXO Provides Stable Reference for High-Quality Timing over IEEE1588
- ◆ Connectors and Component Sites for Alternate Oscillators as Needed
- ◆ Included Universal 5V Power Supply
- ◆ Jumpers to Configure Reset State of MAX24288, GPIO Termination, Ethernet Switch Mode and More
- ◆ LEDs for Power Supplies Valid and Port Status
- ◆ Soldered MAX24288 for Best Signal Integrity
- ◆ Easy-to-Read Silkscreen Labels Identify the Signals Associated with All Connectors, Jumpers, and LEDs
- ◆ Windows®-Based Evaluation Software Provides Easy Configuration and Monitoring of the MAX24288 Device
- ◆ Evaluation Software Calls MAX24288 HAL Software and Structure is Similar to HAL Software

Minimum System Requirements

- ◆ PC Running Windows XP or later
- ◆ Available USB Port

Contents

1. Board Floorplan	4
2. Connections to the Board	5
2.1 Power-Supply Connection	5
2.2 USB Connection	5
2.3 Ethernet Connections and IP Addresses.....	5
2.4 Example Setup.....	5
3. Installing the Software	5
3.1 Troubleshooting Software Installation.....	6
4. Running the Software	6
5. Software User Interface.....	7
5.1 Status Display	7
5.2 Configuration Menu and Command Prompt.....	8
5.2.1 Navigating Menus and Changing Settings.....	8
5.2.2 Configuring the Device.....	8
5.2.3 Other Commands.....	9
5.3 Configuration Menu Detailed Descriptions	9
6. Jumpers, Connectors and LEDs.....	21
7. Component List	26
8. Schematics	28
9. Ordering Information.....	28
10. Revision History	28

List of Figures

Figure 1. MAX24288 EV Kit Board Floorplan	4
Figure 2. Example Setup	5
Figure 3. User Interface Main Screen.....	7

List of Tables

Table 1. Status Display Fields	7
Table 2. MAIN Menu	9
Table 3. CONFIG SCRIPTING Menu	9
Table 4. GPIO PINS Menu	9
Table 5. DATA PATH Menu.....	10
Table 6. 1588 TIME ENGINE Menu	10
Table 7. 1588 EVENT GENERATORS Menu	12
Table 8. PEG1/PEG2 COMMANDS Submenu.....	12
Table 9. 1588 TimestamPERS Menu	12
Table 10. PACKET TS FIFO ENABLES Submenu	13
Table 11. 1588 PACKET CLASSIFIERS Menu.....	13
Table 12. UID CHECK Menu	14
Table 13. CPC CLASSIFIER Menu	14
Table 14. 1588 ON-THE-FLY INSERTION Menu	16
Table 15. ON-THE-FLY CORRECTION Menu.....	18
Table 16. TImESTAMP INSERTION Menu	18
Table 17. LOCK TO PPS Menu.....	19
Table 18. TEST Menu.....	20
Table 19. Power and Reset Components.....	21
Table 20. MAX24288 REFCLK Jumpers and Connectors	21
Table 21. MAX24288 Pin Configuration Jumpers	21
Table 22. MAX24288 Parallel Interface Configuration	23
Table 23. MAX24288 GPIO1 Jumpers and Connectors	23
Table 24. MAX24288 GPIO2 Jumpers and Connectors	23
Table 25. MAX24288 GPIO3 Jumpers and Connectors	23
Table 26. Processor and Debug Jumpers and Connectors	24
Table 27. Ethernet Switch Jumpers, Connectors and LEDs	24
Table 28. SFP Module Jumpers and LEDs	25

1. Board Floorplan

When the board is oriented as shown in Figure 1, The 5V power supply and USB cable included with the kit are connected to jacks J1 and J2 at the top of the board. An SFP module is inserted into the SFP cage lower-left, and an appropriate cable is connected to the SFP module. The SFP module can be 1000BASE-X optical for a 1000Mbps optical connection, or it can contain a 10/100/1000Mbps copper PHY with an SGMII interface to the MAX24288 and an RJ-45 jack on the other side. The SFP module is the network side of the MAX24288, and timestamping of IEEE1588 messages occurs as packets enter and leave the MAX24288 from/to the SFP module. The board ships with a TCXO mounted in the Y3 oscillator position and a 25MHz XO in the Y1 position. See section 6 for detailed descriptions of the board’s jumpers, connectors and LEDs.

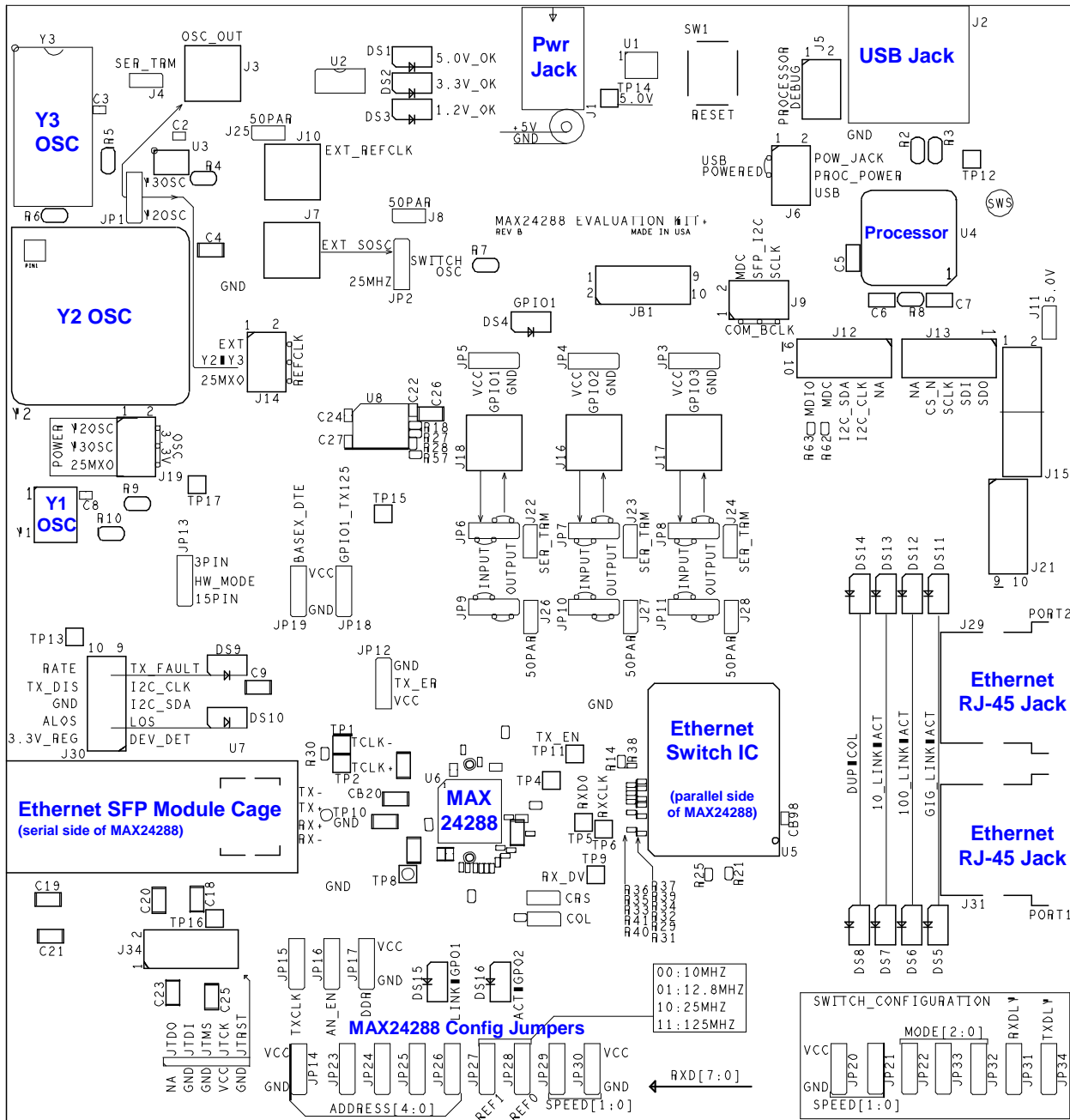

Figure 1. MAX24288 EV Kit Board Floorplan

2. Connections to the Board

2.1 Power-Supply Connection

The board is powered through connector J1 using the provided AC wall-plug 5V power supply. LED DS1 illuminates to indicate that the board is powered.

2.2 USB Connection

The MAX24288 EV kit software application communicates with the EV kit board through USB connector J2.

2.3 Ethernet Connections and IP Addresses

The Ethernet switch on the board, Realtek RTL8363, operates by default as a simple, unmanaged switch. To avoid set-up problems, each system connected to the MAX24288 EV Kit board must have a unique IP address.

2.4 Example Setup

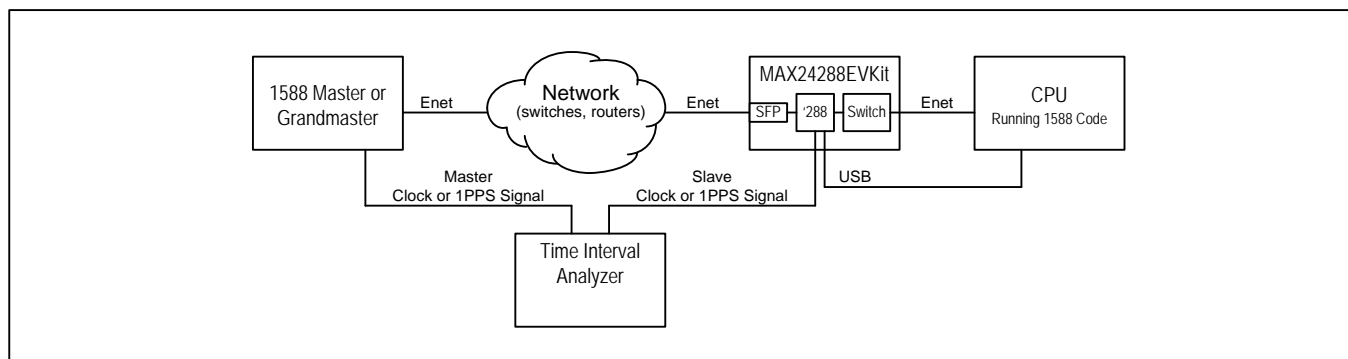

Figure 2. Example Setup

3. Installing the Software

Important Note: Do not connect the board to the PC until after installing the software. The device driver for the USB microcontroller will not be installed correctly.

Follow these steps to install the MAX24288 EV Kit software:

1. To install the software, run `max24288evk.exe`. The latest version of the EV Kit software can be downloaded from the Microsemi website or requested from Microsemi timing products technical support.
2. In the window that indicates the publisher could not be verified, click **Run**.
3. Follow the prompts in the MAX24288 Eval Kit setup wizard, For a default installation, click **Next** three times.
4. Connect the power cord to the J1 connector on the EV Kit board.
5. Connect a USB cable from a USB jack on the PC to the J2 connector on the EV Kit board.
6. In the notification area, Windows will indicate "Installing device driver" and then indicate "Freescale CDC Device (COM6) Device driver software installed successfully."

The text "COM6" indicates the virtual COM port number assigned to the board. This number varies from system to system. Write down the assigned number to use when running the EV Kit software.

If Windows does not show the messages above then verify that the board is powered and is connected to the PC. If the board was already connected to the PC before installing the software then see follow the troubleshooting steps in section 3.1.

3.1 Troubleshooting Software Installation

If the board was connected to the PC before installing the software or if the EV kit software does not list the board's COM port number as an option, then follow these steps:

1. In Windows, go to the Device Manager. In recent versions of Windows this is done by going to **Control Panel** and double-clicking **System**. Then in the upper-left corner click **Device Manager**.
2. In the Device Manager window, under **Other devices**, right-click on **Unknown device** and select **Uninstall**. In the **Confirm Device Uninstall** pop-up click **OK**.
3. In **Control Panel** double-click **Programs and Features**.
4. Right-click on **MAX24288 Eval Kit** and select **Uninstall**.
5. Disconnect power and USB cables from the EV Kit board.
6. Follow the steps in section [3](#).

4. Running the Software

To run the software, double-click on the **MAX24288 Eval Kit** shortcut on the desktop, or in the Windows Start menu, select **All Programs** → **Microsemi** → **MAX24288 Eval Kit**.

At the prompt enter the COM port number assigned to the board in step 6 in section [3](#).

The software then displays its main menu, as shown in [Figure 3](#).

To start communication with the MAX24288 on the EV kit board, type **1** then **Enter** to create the MAX24288 HAL. If the software and the USB device driver have been installed correctly then regular screen updates begin, the **TE SEC** field increments once per second, and **TE NS** fields displays ever-changing values.

If the software exits unexpectedly then run the software again and specify a different COM port number. If none of the listed COM port numbers is correct then follow the troubleshooting steps in section [3.1](#).

5. Software User Interface

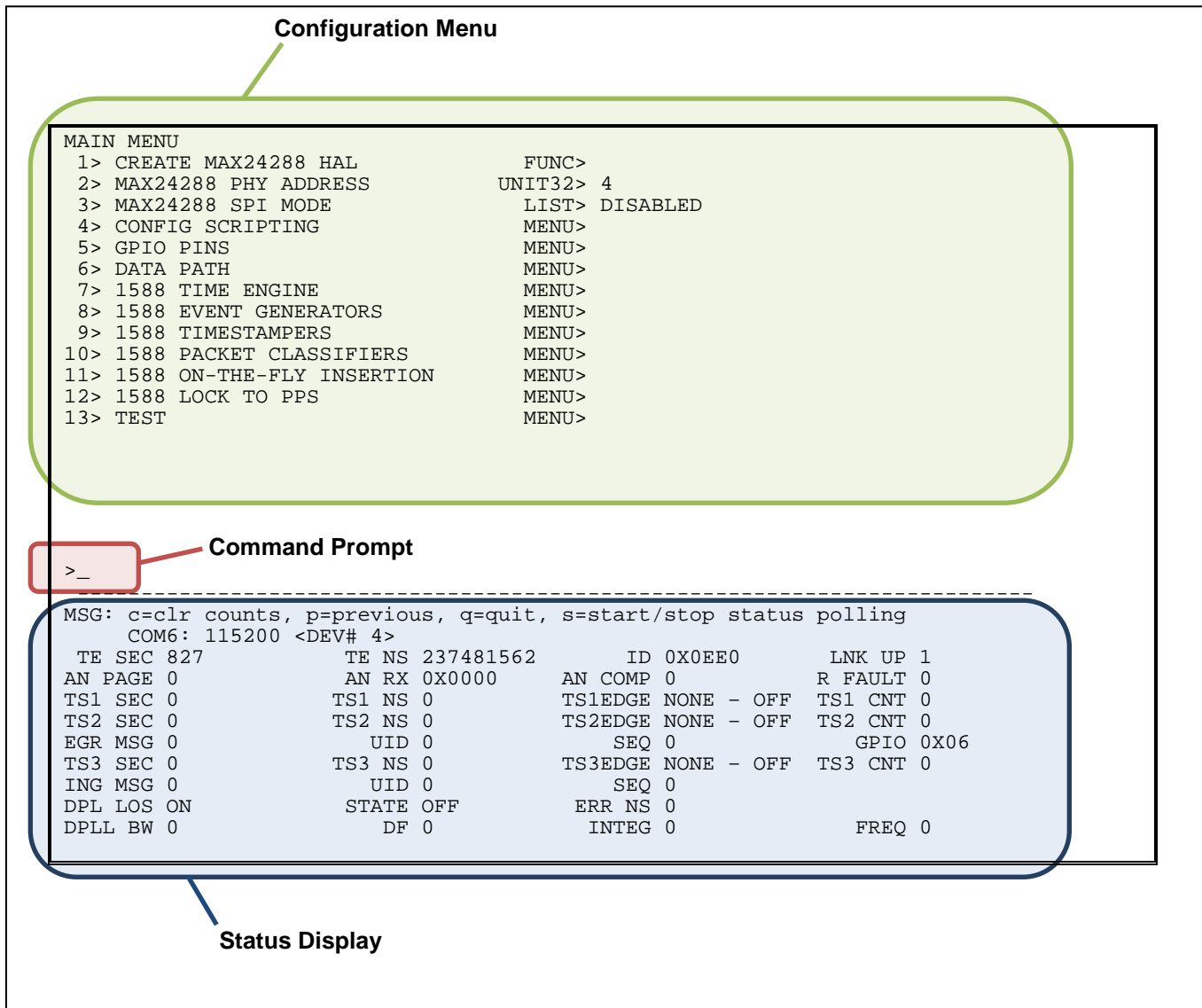

Figure 3. User Interface Main Screen

5.1 Status Display

The status display area (see the bottom of Figure 3) shows the latest data polled from the device. To start software polling and updating of these fields, select **CREATE MAX24288 HAL** in the main menu. To start or stop polling, use the **s** command at the command prompt. Table 1 lists and describes the status display fields.

Table 1. Status Display Fields

Row	Field	Description
1	TE SEC	Time engine seconds field
1	TE NS	Time engine nanosecond field
1	ID	Value read from the MAX24288 ID register
1	LNK UP	Link Up, MAX24288 BMSR register bit 2, 1=link up
2	AN PAGE	Auto-negotiation page available, 1=yes
2	AN RX	Auto-negotiation receiver register value
2	AN COMP	Auto-negotiation complete, MAX24288 BMSR register bit 5, 1=complete

Row	Field	Description
2	R FAULT	Remote fault, MAX24288 BMSR register bit 4
3	TS1 SEC	Timestamp 1, timestamp seconds field
3	TS1 NS	Timestamp 1, timestamp nanoseconds field
3	TS1EDGE	Timestamp 1, timestamp edge type, 0=falling, 1=rising
3	TS1 CNT	Count of timestamps done by timestamp 1 since HAL started or last c command.
4	TS2 SEC	Timestamp 2, timestamp seconds field
4	TS2 NS	Timestamp 2, timestamp nanoseconds field
4	TS2EDGE	Timestamp 2, timestamp edge type, 0=falling, 1=rising
4	TS2 CNT	Timestamp 2, count of timestamps done since HAL started or last c command
5	EGR MSG	Timestamp 2, 4-bit egress PTP messageType field
5	EGR UID	Timestamp 2, 12-bit egress PTP identity code. See MAX24288 data sheet section 6.13.5
5	EGR SEQ	Timestamp 2, 16-bit egress PTP sequenceID field
5	GPIO	MAX24288 GPIO status register (GPIOISR) bits 6:0
6	TS3 SEC	Timestamp 3, timestamp seconds field
6	TS3 NS	Timestamp 3, timestamp nanoseconds field
6	TS3EDGE	Timestamp 3, timestamp edge type, 0=falling, 1=rising
6	TS3 CNT	Timestamp 3, count of timestamps done since HAL started or last c command.
7	ING MSG	Timestamp 3, 4-bit ingress PTP messageType field
7	ING UID	Timestamp 3, 12-bit ingress PTP identity code. See MAX24288 data sheet section 6.13.5
7	ING SEQ	Timestamp 3, 16-bit ingress PTP sequenceID field.
8	DPL LOS	Hardware/Software DPLL loss of signal
8	STATE	Hardware/Software DPLL state
8	ERR NS	Hardware/Software DPLL time error in nanoseconds
9	DPLL BW	Hardware/Software DPLL bandwidth
9	DF	Hardware/Software DPLL damping factor
9	INTEG	Hardware/Software DPLL integral path control
9	FREQ	Hardware/Software DPLL frequency control

5.2 Configuration Menu and Command Prompt

5.2.1 Navigating Menus and Changing Settings

Figure 3 shows the main screen of the MAX24288 software. In the upper half of the screen the command menu has two columns. The left-hand column shows numbered command/menu options. The right-hand column indicates what happens when an option is chosen. **FUNC>** indicates that a function is executed, **LIST>** indicates a list of choices will be presented, and **MENU>** indicates that the user will be taken to a submenu. Data types such as **UINT32>** or **STR>** indicate that a value with the specified data type can be entered. **UINT32>**, for example, means a 32-bit unsigned integer. **STR>** means text string.

To change the device configuration, the user types a number at the command prompt followed by the **Enter** key. If the option selected has a data type in the right-hand column, such as **UINT32>** then the cursor moves to the right of the data type. The user then enters the desired value followed by the **Enter** key. The cursor then moves back to the command prompt area.

If the option selected has **LIST>** in the right-hand column, then the cursor moves to the right of the **LIST>** text and a list of options is shown in an additional column on the right. The user then enters the option number from the list followed by the **Enter** key. The value next to **LIST>** then changes to the option selected, and the cursor moves back to the command prompt area.

5.2.2 Configuring the Device

All menus of the software are designed to have a two-step configuration process:

1. Configure the relevant values using data-type or **LIST>** menu options.
2. Configure the HAL or the device using a **FUNC>** menu option.

For example, in the main menu the PHY address and SPI mode are configured first, and then **CREATE MAX24288 HAL** is selected. As another example, in the **DATA PATH** menu, **AUTO-NEGOTIATE MODE** and **AUTO-NEGOTIATE ADVERT** are configure first, and then **CONFIG AUTO-NEGOTIATE** is selected.

5.2.3 Other Commands

In addition to menu item numbers, the following commands are also valid at the command prompt:

- c** – clear counts in status area
- p** – return to previous menu (when in a submenu)
- q** – quit the program
- s** – stop/start status polling

5.3 Configuration Menu Detailed Descriptions

Table 2. MAIN Menu

Name	Description
CREATE MAX24288 HAL	This function creates the MAX24288 HAL and starts polling device status. The three MAX24288* fields below must be set before this function is executed.
MAX24288 PHY ADDRESS	Specifies the address of the MAX24288 on the MDIO bus to the HAL. The MAX24288 gets its PHY address from pins RXD[7:4] and RX_ER when the MAX24288 RST_N pin is asserted.
MAX24288 SPI MODE	Disable/Enable. <i>Affects MAX24288 register bit PAGESEL.SPI_DIS.</i>
CONFIG SCRIPTING	Opens the CONFIG SCRIPTING menu. See Table 3 .
GPIO PINS	Opens the GPIO PINS menu. See Table 4 .
DATA PATH	Opens the DATA PATH menu. See Table 5 .
1588 TIME ENGINE	Opens the 1588 TIME ENGINE menu. See Table 6 .
1588 EVENT GENERATORS	Opens the 1588 EVENT GENERATORS menu. See Table 7 .
1588 TimestamPERS	Opens the 1588 TimestamPERS menu. See Table 9 .
1588 PACKET CLASSIFIERS	Opens the 1588 PACKET CLASSIFIERS menu. See Table 11 .
1588 ON-THE-FLY INSERTION	Opens the 1588 ON-THE-FLY INSERTION menu. See Table 14 .
1588 LOCK TO PPS	Opens the 1588 LOCK TO PPS menu. See Table 17 .
TEST	Opens the TEST menu. See Table 18 .

Table 3. CONFIG SCRIPTING Menu

Name	Description
READ CONFIGURATION	Function reads configuration information from the file specified by the READ CONFIG FILE NAME parameter below.
WRITE CONFIGURATION	Function writes configuration information to the file specified by the WRITE CONFIG FILE NAME parameter below.
READ CONFIG FILE NAME	The file name for the READ CONFIGURATION function above. The file extension is .cfg.
WRITE CONFIG FILE NAME	The file name for the WRITE CONFIGURATION function above. The file extension is .cfg.

Table 4. GPIO PINS Menu

Name	Description
CONFIG GPIO	Function writes GPIO configuration from the fields below to MAX24288 register GPIOCR1 or GPIOCR2 for the pin(s) specified by GPIO CONFIG SELECT below.
GPIO CONFIG SELECT	Specifies one or all of {GPO1, GPO2, GPIO1-7} to be configured by the CONFIG GPIO function above.
GPOx MODE, GPIOx MODE (9 fields total)	Specify high-impedance, low, high, and several other options. Other options are pin-dependent and include: INT = interrupt output EXT CLK = Output the PTP_CLKO signal from the time engine REFCLK PLL 125 MHZ = Output 125MHz from the reference clock PLL RX 125/25 MHZ = Output clock from receive clock recovery PLL; the frequency is specified by GPIO RX PLL CLK MODE in the DATA PATH menu. RX 125/25 MHZ SQUELCH = same as RX 125/25 MHZ above and the output clock

Name	Description
	signal is squelched when certain receiver conditions occur such as LOS or ALOS LOS or ALOS = Output real-time link status, 1= link up CRS = Output carrier sense status PEG1 = Output signal generated by Programmable Event Generator 1 PEG2 = Output signal generated by Programmable Event Generator 2 See Table 6-4 through Table 6-6 in the MAX24288 data sheet. Note that GPIO4 through GPIO7 are the TXD4 through TXD7 pins, which are not available when the parallel MII interface is configured as GMII.

Table 5. DATA PATH Menu

Name	Description
CONFIG DATA PATH	Function writes configuration from fields LOOPBACK MODE through TXCLK PIN 125MHZ below to MAX24288 registers.
DEVICE DATA PATH MODE	Specifies the combination of serial interface type, parallel interface type and interface speeds. Examples include (1) GMII ↔SGMII (1000Mbps) and (2) RGMII10 ↔SGMII (10Mbps). <i>Affects MAX24288 register fields PCSCR.BASEX, GMIICR.SPD, GMIICR.DTE_DCE, and GMIICR.DDR.</i>
LOOPBACK MODE	Controls loopback modes. See the block diagram in the MAX24288 data sheet for loopback locations. <i>Affects register fields BMCR.DLB, PCSCR.TLB, GMIICR.RLB, CR.DLBDO, CR.RLBDO, CR.TLBDO.</i>
SERIAL TCLK PIN MODE	Enables/disables the TCLKP/N differential pair. <i>Affects register field CR.TCLK_EN.</i>
GPIO RX PLL CLK MODE	Specifies the frequency, 25MHz or 125MHz, of the receive recovered clock that can be output on GPIO pins. Also specifies whether this clock is squelched when any of several conditions occur, such as Rx loss of signal. <i>Affects register fields CR.RCFREQ and CR.RCSQL.</i>
TXCLK PIN 125MHZ	In GMII and RGMII modes, the TXCLK pin is not used for parallel interface operation. The TXCLK_EN bit enables TXCLK to output a 125MHz clock from the TX PLL in those modes. TXCLK_EN is ignored in MII mode. <i>Affects register field GMIICR.TXCLK_EN.</i>
CONFIG DIAG PATTERN	Function writes configuration from fields DIAGNOSTIC PATTERN MODE and CUSTOM 10-BIT PATTERN to MAX24288 registers.
DIAGNOSTIC PATTERN MODE	Specifies a diagnostic pattern transmit, typically for jitter testing. <i>Affects register fields JIT_DIAG.JIT_EN, JIT_DIAG.JIT_PAT.</i>
CUSTOM 10-BIT PATTERN	Specifies a custom 10-bit diagnostic pattern. <i>Affects register field JIT_DIAG.CUST_PAT.</i>
CONFIG AUTO-NEGOTIATE	Function writes configuration from AUTO-NEGOTIATE MODE and AUTO-NEGOTIATE ADVERT to MAX24288 registers.
AUTO-NEGOTIATE MODE	Enables/disables MAX24288 auto-negotiation. <i>Affects register fields BMCR.AN_EN and AN_START.</i>
AUTO-NEGOTIATE ADVERT	Specifies the auto-negotiation tx_Config_Reg[15:0] value for the MAX24288. <i>Affects register field AN_ADV.</i>

Table 6. 1588 TIME ENGINE Menu

Name	Description
SET TIME	Function writes time from TIME SEC and TIME NS below to the MAX24288 time engine.
TIME SEC	Specifies the seconds portion of the time for the SET TIME function above. <i>Affects the MAX24288 TIME register field.</i>
TIME NS	Specifies the nanoseconds portion of the time for the SET TIME function above. <i>Affects the MAX24288 TIME register field.</i>
SET FREQ OFFSET	Function adjusts the MAX24288 PERIOD register from its nominal value of 8.0ns by the amount specified in the FREQ OFFSET field below.
FREQ OFFSET +/- PPT	Specifies a time engine frequency offset in parts per trillion (PPT). <i>Affects the MAX24288 PERIOD register field.</i>
DO TIME BUILD OUT	Function adjusts MAX24288 time engine time smoothly. Time is advanced by the amount specified by TBO ADJUSTMENT (below) over a duration specified by TBO DURATION (below). For example, if TBO ADJUSTMENT is 100ns and TBO DURATION is 1s then DO TIME BUILD OUT advances time in the MAX24288 time engine by an extra 100ns, but it does this extra advance at a rate of

Name	Description
	100ns/1s=0.1ppm. DO TIME BUILD OUT makes one-time or repeated used of the precise time adjustment feature described in section 6.13.1.3 of the MAX24288 data sheet. <i>Affects register fields PER_ADJ and ADJ_CNT.</i>
TBO DURATION +/- NS	Specifies the total time duration during which the time is adjusted by the DO TIME BUILD OUT function above.
TBO ADJUSTMENT +/- NS	Specifies the total time adjustment desired for the DO TIME BUILD OUT function above.
CONFIG EXT CLK & PTP_CLKO	Function configures the MAX24288 external clock and PTP_CLKO output clock features using the settings of the EXT CLK SOURCE through PTP_CLKO INVERT fields below. See MAX24288 data sheet section 6.13.1.4 for more information about the external clock syntonization feature. See MAX24288 data sheet section 6.13.2 for more information about the PTP_CLKO output clock.
EXT CLK SOURCE	Specifies the input signal pin for the MAX24288 external clock syntonization feature. <i>Affects register field PTPCR3.EXT_SRC.</i>
EXT CLK ENABLE	Enable/disable control for the MAX24288 external clock syntonization feature. <i>Affects register field PTPCR3.EXT_CLK_ENA.</i>
EXT CLK DIVIDE	Specifies the external clock divider value. <i>Affects register field PTPCR3.EXT_DIV.</i>
EXT CLK LIMIT	Specifies the maximum number of nanoseconds to adjust the time engine accumulator period from the nominal value set by the MAX24288 PERIOD register. <i>Affects register field PTPCR3.EXT_LIM.</i>
EXT CLK PER NS (16-255)	Specifies the period of the external clock after being divided by the EXT CLK DIVIDE value. <i>Affects register field PTPCR3.EXT_PER.</i>
PTP_CLKO DIVIDE (0=NO DIV)	Specifies the divide value for the PTP_CLKO signal. PTP_CLKO frequency is 125MHz divided by this value. <i>Affects register field PTPCR2.CLKO_DIV.</i>
PTP_CLKO INVERT	Invert/non-invert control. <i>Affects register field PTPCR2.CLKO_INV.</i>

Table 7. 1588 EVENT GENERATORS Menu

Name	Description
CONFIG PEG	Function configures the MAX24288 programmable event generator(s) (PEGs) using settings from the fields below and the PEG1 COMMANDS and PEG2 COMMANDS submenus.
PEG CONFIG SELECT	Specifies one or both of the PEGs to be configured by the CONFIG PEG function above.
PEG1 MODE	Allows the user to specify that PEG1 generate one of several common clock frequencies from 0.5Hz through 31.25MHz. If the CUSTOM option is selected then the user can specify a custom PEG command script in the PEG1 COMMANDS submenu.
PEG1 OFFSET NS	When PEG1 MODE≠CUSTOM then this field specifies an offset from the one-second boundary for the first edge generated by the PEG. If PEG1 OFFSET=0 then PEG1 is configured to generate the first output signal edge when the time engine's nanosecond field equals 0. If, for example, PEG1 OFFSET=-10 then PEG1 is configured to generate the first output signal edge when the time engine's nanoseconds field equals 999,999,990 (i.e. 10ns before the nanoseconds field rolls over to 0).
PEG2 MODE	Same as PEG1 MODE above but for PEG2.
PEG2 OFFSET NS	Same as PEG1 OFFSET above but for PEG2.
PEG1 COMMANDS	Opens the PEG1 COMMANDS Menu where a custom PEG1 command script can be entered. See Table 8 .
PEG2 COMMANDS	Same as PEG1 COMMANDS above but for PEG2.

Table 8. PEG1/PEG2 COMMANDS Submenu

Name	Description
CMD RESOLUTION	Specifies 1ns or 1/256ns resolution for the 16-bit and 32-bit relative time commands written to the PEG command FIFO. <i>Affects register field PEGCR.P1RES for PEG1 and PEGCR.P2RES for PEG2.</i>
CMD WORD LENGTH	Specifies the number of words of CMD WOR 0 through CMD WORD 15 below that the software should write to the PEG command FIFO. CMD WORD LENGTH=1 indicates that only CMD WORD 0 should be written. CMD WORD LENGTH=4 indicates that CMD WORD 0 through CMD WORD 3 should be written.
CMD WORD 0 – CMD WORD 15	Specifies up to 16 entries to be written to the PEG command FIFO. The CMD WORD LENGTH field above specifies the number of entries that are written to the PEG command FIFO.

Table 9. 1588 TIMESTAMPERS Menu

Name	Description
CONFIG TS	Function configures the MAX24288 timestampers using settings from the fields below and the PACKET TS FIFO ENABLES submenu.
TS CONFIG SELECT	Specifies one or all of the timestampers to be configured by the CONFIG TS function above. The “with PTP HDR” options tell the software that PTP packets (rather than input signal edges) are being timestamped by TS2 or TS3. Therefore, when software reads each timestamp it should also read the HDR_DAT1 and HDR_DAT2 registers to get packet ID information.
TS1 SOURCE	Specifies the source of the signal to be timestamped by timestamp 1. <i>Affects register field TSCR.TS1SRC_SEL.</i>
TS1 EDGE	Specifies whether positive edges, negative edges or both should be timestamped by timestamp 1. <i>Affects register field TSCR.TS1EDGE.</i>
TS1 OFFSET NS	Specifies an offset in nanoseconds that software adds to each timestamp generated by the MAX24288. This field allows software to correct for cable delays, signal skews, etc.
TS1 DIVIDER 1	Specifies the timestamp 1 divider 1 setting. One or both of the TS1 dividers can be used to divide down the frequency of the input signal that goes to timestamp 1 in order to reduce the number of edges that must be timestamped. The input signal frequency is divided by value entered + 1. <i>Affects register field TS1_DIV1.</i>
TS1 DIVIDER 2	Specifies the timestamp 1 divider 2 setting. <i>Affects register field TSCR.TS2SRC_SEL.</i>
TS2 SOURCE	Specifies the source of the signal to be timestamped by timestamp 2. <i>Affects register field TSCR.TS2SRC_SEL.</i>
TS2 EDGE	Specifies whether positive edges, negative edges or both should be timestamped by

Name	Description
	timestamp 2. <i>Affects register field TSCR.TS2EDGE.</i>
TS2 OFFSET NS	Same as TS1 OFFSET NS above but for timestamp 2.
TS3 SOURCE	Specifies the source of the signal to be timestamped by timestamp 3. <i>Affects register field TSCR.TS3SRC_SEL.</i>
TS3 EDGE	Specifies whether positive edges, negative edges or both should be timestamped by timestamp 3. <i>Affects register field TSCR.TS3EDGE.</i>
TS3 OFFSET NS	Same as TS1 OFFSET NS above but for timestamp 3.
TS3 GATED BY TS1	See section 6.13.8 of the MAX24288 data sheet. <i>Affects register field PTPCR1.TS3_FIFO.</i>
PACKET TS FIFO ENABLES	Opens the PACKET TS FIFO ENABLES Menu. This menu has enable/disable fields that specify, for each PTP message type, whether timestamps are written to the timestamp FIFO. See Table 10 .

Table 10. PACKET TS FIFO ENABLES Submenu

Name	Description
TS2 EGRESS MSG0 (SYNC)	Controls whether timestamps for egress PTP Sync messages are written to the TS2 timestamp FIFO. <i>Affects register field TS_FIFO_EN.EM0_EN.</i>
TS2 EGRESS MSG1 (DLY REQ)	Same as above but for egress PTP Delay_Req messages. <i>Affects register field TS_FIFO_EN.EM1_EN.</i>
TS2 EGRESS MSG2 (PDLY REQ)	Same as above but for egress PTP Pdelay_Req messages. <i>Affects register field TS_FIFO_EN.EM2_EN.</i>
TS2 EGRESS MSG3 (PDLY RSP)	Same as above but for egress PTP Pdelay_Resp messages. <i>Affects register field TS_FIFO_EN.EM3_EN.</i>
TS2 EGRESS MSG4 ENABLE – TS2 EGRESS MSG7 ENABLE	Same as above but for egress PTP message types 4 through 7, which are currently not defined for PTPv2. <i>Affects register field TS_FIFO_EN.EM4_EN through EM7_EN.</i>
TS3 INGRESS MSG0 (SYNC)	Controls whether timestamps for ingress PTP SYNC messages are written to the TS2 timestamp FIFO. <i>Affects register field TS_FIFO_EN.IM0_EN.</i>
TS3 INGRESS MSG1 (DLY REQ)	Same as above but for ingress PTP Delay_Req messages. <i>Affects register field TS_FIFO_EN.IM1_EN.</i>
TS3 INGRESS MSG2 (PDLY REQ)	Same as above but for ingress PTP Pdelay_Req messages. <i>Affects register field TS_FIFO_EN.IM2_EN.</i>
TS3 INGRESS MSG3 (PDLY RSP)	Same as above but for ingress PTP Pdelay_Resp messages. <i>Affects register field TS_FIFO_EN.IM3_EN.</i>
TS3 INGRESS MSG4 ENABLE – TS2 INGRESS MSG7 ENABLE	Same as above but for ingress PTP message types 4 through 7, which are currently not defined for PTPv2. <i>Affects register field TS_FIFO_EN.IM4_EN through IM7_EN.</i>

Table 11. 1588 PACKET CLASSIFIERS Menu

Name	Description
CONFIG PACKET CLASSIFIER	Function configures the MAX24288 packet classifiers using settings from the fields below and the UID CHECK and CPC CLASSIFIER submenus.
ENET PTP HW CLASS ENABLE	Controls whether the hardwired packet classifier looks for PTP messages in Ethernet frames with Ethertype=0x88F7. <i>Affects register field PKT_CLASS.ENET.</i>
ENET CFG HW CLASS ENABLE	Controls whether the hardwired packet classifier looks for PTP messages in Ethernet frames with Ethertype=ENET CFG ETYPE below. <i>Affects register field PKT_CLASS.ENET_CFG.</i>
ENET CFG ETYPE	Specifies the alternate Ethertype used by the hardwired packet classifier when ENET CFG HW CLASS ENABLE is set to ON. <i>Affects register field ETYPE_ALT.</i>
IPV4 UDP HW CLASS ENABLE	Controls whether the hardwired packet classifier looks for PTP messages in IPv4/UDP packets. <i>Affects register field PKT_CLASS.UDP_IPv4.</i>
IPV6 UDP HW CLASS ENABLE	Controls whether the hardwired packet classifier looks for PTP messages in IPv6/UDP packets. <i>Affects register field PKT_CLASS.UDP_IPv6.</i>

Name	Description
UDP SRC PORT	IP/UDP packets must have a UDP source port number that matches this field to be qualified. A value of 0xFFFF disables UDP source port matching. <i>Affects register field UDP_SRC.</i>
UDP DST PORT	IP/UDP packets must have a UDP destination port number that matches this field to be qualified. A value of 0xFFFF disables UDP destination port matching. <i>Affects register field UDP_DST.</i>
MPLS UCAST HW CLASS ENABLE	Controls whether the hardwired packet classifier looks for PTP messages in MPLS unicast packets. <i>Affects register field PKT_CLASS.MPLS_UCAST.</i>
MPLS MCAST HW CLASS ENABLE	Controls whether the hardwired packet classifier looks for PTP messages in MPLS multicast packets. <i>Affects register field PKT_CLASS.MPLS_MCAST.</i>
MPLS HW LABEL (20 BIT)	MPLS packets must have an inner label that matches this field to be qualified. <i>Affects register fields MPLS_LABEL_HI and MPLS_LABEL_LO.</i>
MEF CFG HW CLASS ENABLE	Controls whether the hardwired packet classifier looks for PTP messages in MEF pseudowire packets. <i>Affects register field PKT_CLASS.MEF_CFG.</i>
MEF CFG HW ECID (20 BIT)	MEF pseudowires must have an ECID that matches this field to be qualified. <i>Affects register fields MEF_ECID_HI and MEF_ECID_LO.</i>
VLAN2 ID	Specifies an alternate (optional) Ethertype for VLAN headers. Should be set to 0x8100 to not specify an alternate Ethertype. <i>Affects register fields VLAN2_ID.</i>
PTP VERSION (0-7)	Packets must have versionPTP field “match” this field to be qualified. The definition of “match” is specified by PTP VERSION CHECK MODE below. <i>Affects register fields PKT_CLASS.PTP_VERSION.</i>
PTP VERSION CHECK MODE	Specifies how a packet’s versionPTP field is compared to the PTP VERSION field above. Two options are available: (1) version must be less than or equal to PTP VERSION, or (2) version must exactly match. <i>Affects register fields PKT_CLASS.VER_EXACT.</i>
UID CHECK	Opens the UID CHECK Menu. See Table 12 .
CPC CLASSIFIER	Opens the CPC CLASSIFIER Menu. See Table 13 .

Table 12. UID CHECK Menu

Name	Description
CONFIG PACKET CLASSIFIER	Same function as in Table 11 above.
UID CHECK ENABLE	Enables/disables UID checking for ingress PTP messages. Each PTP package has a 10 byte field in the header called the sourcePortIdentity field. This field consists of an eight byte clockIdentity and a two byte portNumber. When UID checking is enabled the MAX24288 calculates a 12-bit code from the sourcePortIdentity field of each ingress packet and compares it to a stored 12-bit code (the UID IDENTITY CODE below). The 12-bit code must match for the message timestamp to be stored in the TS3 FIFO. See section 6.13.6.4 of the MAX24288 data sheet for details. <i>Affects register field UID_CHK.CHK_EN.</i>
UID IDENTITY CODE (12 BITS)	Specifies the stored 12-bit code mentioned above. This field is automatically updated when the COMPUTE UID function is selected below. <i>Affects register field UID_CHK.UID.</i>
COMPUTE UID	Function calculates the 12-bit UID IDENTITY CODE above from the CLOCK ID and PORT NUMBER fields below.
CLOCK ID (16 HEX DIGITS)	One of two ways to specify the sourcePortIdentity.clockIdentity field from which the UID IDENTITY CODE above is computed. When 16 hexadecimal digits are entered, the equivalent ASCII string is calculated and displayed in the CLOCK ID (8 CHARS) field below.
CLOCK ID (8 CHARS)	The second of two ways to specify the sourcePortIdentity.clockIdentity field. When a string is entered, the hex equivalent is calculated and displayed in the CLOCK ID (16 HEX DIGITS) field above.
PORT NUMBER	Specifies the sourcePortIdentity.portNumber field from which the UID IDENTITY CODE above is computed.

Table 13. CPC CLASSIFIER Menu

Name	Description
CONFIG PACKET CLASSIFIER	Same function as in Table 11 above.

Name	Description
CPC MODE	Specifies AND mode or OR mode. In AND mode the hardwired packet classifier (HPC) and the configurable packet classifier (CPC) must both match to qualify the packet. In OR mode either the HPC or the CPC must match. <i>Affects register fields PKT_CLASS.CFG_OR and PTPCR1.TOP_MODE.</i>
CPC START POSITION	Specifies the position in the packet from which CPC offsets (below) are calculated. <i>Affects register field PKT_CLASS.CFG_START.</i>
CPC PTP HEADER OFFSET	When CPC MODE is set to OR this field must be set to specify the offset from the CPC START POSITION (above) to the start of the PTP message header. <i>Affects register CFG_OFFSET through which the indirect register PTP_OFFSET is written.</i>
CPC #0 OFFSET	See section 6.13.6.2 in the MAX24288 data sheet for details. The CPC has eight bit-maskable 16-bit matching criteria, any or all of which can be used to set up packet qualification criteria. This field specifies the offset from the CPC START POSITION (above) to the comparison point for comparison #0. <i>Affects register CFG_OFFSET.</i>
CPC #0 MASK	Specifies which bits should be compared for comparison #0. <i>Affects register CFG_MASK.</i>
CPC #0 MATCH	Specifies the required values of the bits to be compared for comparison #0. <i>Affects register CFG_MATCH.</i>
CPC #1 OFFSET	Same as CPC #0 OFFSET above but for CPC #1.
CPC #1 MASK	Same as CPC #0 MASK above but for CPC #1.
CPC #1 MATCH	Same as CPC #0 MATCH above but for CPC #1.
CPC #2 OFFSET	Same as CPC #0 OFFSET above but for CPC #2.
CPC #2 MASK	Same as CPC #0 MASK above but for CPC #2.
CPC #2 MATCH	Same as CPC #0 MATCH above but for CPC #2.
CPC #3 OFFSET	Same as CPC #0 OFFSET above but for CPC #3.
CPC #3 MASK	Same as CPC #0 MASK above but for CPC #3.
CPC #3 MATCH	Same as CPC #0 MATCH above but for CPC #3.
CPC 4-7	Opens the CPC CLASSIFIER 4-7 menu, which is exactly the same as the CPC CLASSIFIER 0-3 menu but corresponds to CPC classifiers 4-7.

Table 14. 1588 ON-THE-FLY INSERTION Menu

Name	Description
CONFIG ON-THE-FLY	Function configures the MAX24288 on-the-fly packet modifier logic using settings from the fields below and the ON-THE-FLY CORRECTION and TIMESTAMP INSERTION submenus.
TRANSPARENT CLOCK MODE	<p>MANUAL: User configures all transparent clock on-the-fly behavior using other settings in the 1588 ON-THE-FLY menu and submenus.</p> <p>END TO END: Sets up typical E2E TC configuration: <i>Sets TS_INSERT_EN.TC_CF_EN to enable one-step TC residence time correction for Sync and Delay_Req messages.</i> <i>Writes software TC ASYMM CORRECTION value to CF_COR1 register.</i> <i>Sets CF_INGRESS.IM0_CF to add CF_COR1 to correctionField of ingress Sync messages.</i> <i>Sets CF_EGRESS.EM1_CF to subtract CF_COR1 from correctionField of egress Delay_Req messages.</i></p> <p>END TO END + PDELAY CORR: Same configuration as END TO END above plus: <i>Sets TS_INSERT_EN.TC_CF_PD to enable one-step TC residence time correction for Pdelay_Req and Pdelay_Resp messages.</i> <i>Sets CF_EGRESS.EM2_CF to subtract CF_COR1 from correctionField of egress Pdelay_Req messages.</i> <i>Sets CF_INGRESS.IM3_CF to add CF_COR1 to correctionField of ingress Pdelay_Resp messages.</i></p> <p>PEER TO PEER: Sets up typical P2P TC configuration: <i>Sets TS_INSERT_EN.TC_CF_EN to enable one-step TC residence time correction for Sync messages.</i> <i>Sets CF_INGRESS.IM0_CF to add CF_COR1 to correctionField of ingress Sync messages.</i></p>
ORDINARY CLOCK MODE	<p>MANUAL: User configures all ordinary clock on-the-fly behavior using other settings in the 1588 ON-THE-FLY menu and submenus.</p> <p>1 STEP MASTER: Sets up typical configuration for OC master port with one-step operation (i.e. no PTP Follow_Up messages). <i>Sets TS_INSERT_EN.EM0_EN to enable TS insertion into egress Sync messages.</i> <i>Sets TS_INSERT_EN.IM1_EN to enable TS insertion into ingress Delay_Req messages.</i></p> <p>1 STEP SLAVE: Sets up typical configuration for OC slave port with one-step operation (i.e. no PTP Follow_Up messages). <i>Sets TS_INSERT_EN.IM0_EN to enable TS insertion into ingress Sync messages.</i></p> <p>1 STEP SLAVE + MICROSEMI TS INS: Same as 1 STEP SLAVE but also enables Microsemi's method for timestamp insertion into egress Delay_Req messages as described in MAX24288 data sheet section 6.13.7.3. <i>Sets TS_INSERT_EN.IM0_EN to enable TS insertion into ingress Sync messages.</i> <i>Sets TS_INSERT_EN.EM1_EN to enable TS insertion into egress Delay_Req messages.</i></p>
PDELAY_REQ/RESP MODE	<p>MANUAL: User configures all Peer-to-Peer (P2P) behavior using other settings in the 1588 ON-THE-FLY menu and submenus.</p> <p>1 STEP: Sets up typical P2P configuration for one-step operation (i.e. no PTP Pdelay_Resp_Follow_Up messages). <i>Sets TS_INSERT_EN.IM3_EN to enable TS insertion into ingress Pdelay_Resp messages.</i> <i>Sets TS_INSERT_EN.EM3_EN to enable TS insertion into egress Pdelay_Resp messages.</i></p> <p>1 STEP + MICROSEMI TS INS: Same as 1 STEP but also enables Microsemi's method for timestamp insertion into egress Pdelay_Req messages as described in MAX24288 data sheet section 6.13.7.3. <i>Sets TS_INSERT_EN.IM3_EN to enable TS insertion into ingress Pdelay_Resp messages.</i> <i>Sets TS_INSERT_EN.EM3_EN to enable TS insertion into egress Pdelay_Resp messages.</i> <i>Sets TS_INSERT_EN.EM2_EN to enable TS insertion into egress Pdelay_Req messages.</i></p>
TDMOP MODE	Enables a special mode in the MAX24288 to support timestamping circuit emulation

Name	Description
	packets rather than PTP packets. See the MAX24288 data sheet, section 6.13.8. Affects register PTPCR1.TOP_MODE.
CLR TS ON EGRESS	ON = the MAX24288 should clear the bytes specified by the SEC TS OFFSET and NS TS OFFSET fields below in egress messages. Affects register TS_INSERT_EN.CLR_TS_INS.
SEC TS INSERT	When this field is set to a value other than DISABLED the MAX24288 writes 1, 4 or 6 bytes of seconds information from the ingress timestamp into ingress PTP messages at the offset specified by the SEC TS OFFSET field. Only the PTP message types specified in the fields in Table 18 are affected by the timestamp insertion circuitry. Affects register TS_INSERT.SEC_ENA.
SEC TS OFFSET (BYTES)	Specifies the byte offset from the start of the PTP message header to the first byte that should be written with timestamp seconds information. Ignored when SEC TS INSERT = DISABLED. Affects register TS_INSERT.SEC_OFF.
NS TS INSERT	When this field is ENABLED the MAX24288 writes all four bytes of nanoseconds information from the ingress timestamp into ingress PTP messages at the offset specified by the NSEC TS OFFSET field. Only the PTP message types specified in the fields in Table 18 are affected by the timestamp insertion circuitry. Affects register TS_INSERT.NSEC_ENA.
NS TS OFFSET (BYTES)	Specifies the byte offset from the start of the PTP message header to the first byte that should be written with timestamp nanoseconds information. Ignored when NSEC TS INSERT = DISABLED. Affects register TS_INSERT.NSEC_OFF.
TC ASYMM CORRECTION (NS)	Specifies an asymmetry correction value to be written to the MAX24288. Affects register CF_COR1.
TC MEAN PATH DELAY (NS)	Specifies a P2P TC mean path delay value to be written to the MAX24288. In a peer-to-peer transparent clock, the system transmits Pdelay_Req messages to its neighbors, receives Pdelay_Resp messages, and then calculates meanPathDelay as specified in section 11.4.3 of IEEE1588-2008. This meanPathDelay is then added to the correctionField of Sync messages passing through the system. The MAX24288 can add this meanPathDelay value to ingress Sync messages on-the-fly. Affects register MEAN_PATH_DELAY.
ON-THE-FLY CORRECTION	Opens the ON-THE-FLY CORRECTION menu. See Table 17 .
TIMESTAMP INSERTION	Opens the TIMESTAMP INSERTION menu. See Table 18 .

Table 15. ON-THE-FLY CORRECTION Menu

Name	Description
CONFIG ON-THE-FLY	Same function as in Table 14 above.
CORRECTION REG 1 (NS)	One of three correction registers that can be added to the correctionField of ingress messages and subtracted from the correctionField of egress messages as specified by the fields below. <i>Affects register CF_COR1.</i>
CORRECTION REG 2 (NS)	The second of three correction registers. See CORRECTION REG 1 above. <i>Affects register CF_COR2.</i>
CORRECTION REG 3 (NS)	The third of three correction registers. See CORRECTION REG 1 above. <i>Affects register CF_COR3.</i>
INGRESS SYNC CORRECTION	These fields enable on-the-fly correctionField adjustment for ingress type 0 (Sync) through type 7 PTP messages and specify which CORRECTION REG above to add to the correctionField. <i>Affects register fields CF_INGRESS.IM0_CF through IM7_CF.</i>
INGRESS DELAY_REQ CORR	
INGRESS PDELAY_REQ CORR	
INGRESS PDELAY_RESP CORR	
INGRESS MSG 4 CORRECTION	
INGRESS MSG 5 CORRECTION	
INGRESS MSG 6 CORRECTION	
INGRESS MSG 7 CORRECTION	These fields enable on-the-fly correctionField adjustment for egress type 0 (Sync) through type 7 PTP messages and specify which CORRECTION REG above to subtract from the correctionField. <i>Affects register fields CF_EGRESS.EM0_CF through EM7_CF.</i>
EGRESS SYNC CORRECTION	
EGRESS DELAY_REQ CORR	
EGRESS PDELAY_REQ CORR	
EGRESS PDELAY_RESP CORR	
EGRESS MSG 4 CORRECTION	
EGRESS MSG 5 CORRECTION	
EGRESS MSG 6 CORRECTION	
EGRESS MSG 7 CORRECTION	

Table 16. TIMESTAMP INSERTION Menu

Name	Description
CONFIG ON-THE-FLY	Same function as in Table 14 above.
INGRESS SYNC ENABLE	These fields enable on-the-fly timestamp insertion for ingress type 0 (Sync) through type 7 PTP messages. The seconds and nanoseconds portions of the ingress timestamp are written as specified by the SEC TS INSERT, SEC TS OFFSET, NSEC TS INSERT and NSEC TS OFFSET fields in Table 14. <i>Affects register fields TS_INSERT-EN.IM0_EN through IM7_EN.</i>
INGRESS DELAY_REQ EN	
INGRESS PDELAY_REQ EN	
INGRESS PDELAY_RESP EN	
INGRESS MSG 4 ENABLE	
INGRESS MSG 5 ENABLE	
INGRESS MSG 6 ENABLE	
INGRESS MSG 7 ENABLE	

Table 17. LOCK TO PPS Menu

Name	Description																			
CONFIG LOCK TO PPS	Function configures the evaluation software using settings from the fields below to work with the MAX24288 hardware to form a hardware/software PLL that locks to an input 1PPS signal. In this PLL, timestamper 1 (TS1) in the MAX24288 timestamps edges of a 1PPS input signal. The edges of this signal are assumed to occur at the exact one-second boundary. Therefore ideally the timestamp nanoseconds field should be 0. The difference between the nanosecond field and zero is the error information used to control the PLL. Note 1: TS1 must be configured to timestamp an input 1PPS signal in the 1588 TIMESTAMPERS Menu (Table 9) before executing the CONFIG LOCK TO PPS function. Note 2: The evaluation software controls the time and/or frequency of the MAX24288 time engine when PLL MODE below is not OFF. Therefore previous settings of time engine values may be overwritten by the evaluation software when the LOCK TO PPS PLL is enabled.																			
PLL MODE	Specifies operating mode of the hardware/software PLL. <table border="1" data-bbox="529 663 1440 1283"> <thead> <tr> <th data-bbox="535 663 776 690">Mode</th> <th data-bbox="782 663 1433 690">Description</th> </tr> </thead> <tbody> <tr> <td data-bbox="535 699 776 726">OFF</td> <td data-bbox="782 699 1433 726">Disable the PLL</td> </tr> <tr> <td data-bbox="535 730 776 806">FREERUN</td> <td data-bbox="782 730 1433 806">Ignore error information from TS1 and clock the time engine at the frequency specified by the FREE RUN FREQ PPM field below.</td> </tr> <tr> <td data-bbox="535 810 776 974">FREQ MEASURE</td> <td data-bbox="782 810 1433 974" rowspan="6">For debug only. These values force the hardware/software PLL into a particular operating state.</td> </tr> <tr> <td data-bbox="535 840 776 867">FREQ ADJUST</td> </tr> <tr> <td data-bbox="535 871 776 898">TIME ADJUST</td> </tr> <tr> <td data-bbox="535 903 776 930">TIME MEASURE</td> </tr> <tr> <td data-bbox="535 934 776 961">TIME BUILD OUT</td> </tr> <tr> <td data-bbox="535 966 776 993">LOCK</td> </tr> <tr> <td data-bbox="535 997 776 1062">HOLDOVER</td> <td data-bbox="782 997 1433 1062">Ignore error information from TS1 and clock the time engine at a holdover frequency averaged by the evaluation software while the PLL was locked to an input signal.</td> </tr> <tr> <td data-bbox="535 1066 776 1199">AUTO FREQ LOCK</td> <td data-bbox="782 1066 1433 1199">Fully automatic PLL operation with frequency-only locking. When the PLL is locked its output frequency tracks the frequency of the input signal, but time is not adjusted. Therefore the MAX24288 time engine will have a fixed time offset vs. the source of the input signal.</td> </tr> <tr> <td data-bbox="535 1203 776 1283">AUTO TIME LOCK</td> <td data-bbox="782 1203 1433 1283">Fully automatic PLL operation with time-and-frequency locking. When the PLL is locked the time and frequency of the MAX24288 time engine track the input signal.</td> </tr> </tbody> </table>	Mode	Description	OFF	Disable the PLL	FREERUN	Ignore error information from TS1 and clock the time engine at the frequency specified by the FREE RUN FREQ PPM field below.	FREQ MEASURE	For debug only. These values force the hardware/software PLL into a particular operating state.	FREQ ADJUST	TIME ADJUST	TIME MEASURE	TIME BUILD OUT	LOCK	HOLDOVER	Ignore error information from TS1 and clock the time engine at a holdover frequency averaged by the evaluation software while the PLL was locked to an input signal.	AUTO FREQ LOCK	Fully automatic PLL operation with frequency-only locking. When the PLL is locked its output frequency tracks the frequency of the input signal, but time is not adjusted. Therefore the MAX24288 time engine will have a fixed time offset vs. the source of the input signal.	AUTO TIME LOCK	Fully automatic PLL operation with time-and-frequency locking. When the PLL is locked the time and frequency of the MAX24288 time engine track the input signal.
Mode	Description																			
OFF	Disable the PLL																			
FREERUN	Ignore error information from TS1 and clock the time engine at the frequency specified by the FREE RUN FREQ PPM field below.																			
FREQ MEASURE	For debug only. These values force the hardware/software PLL into a particular operating state.																			
FREQ ADJUST																				
TIME ADJUST																				
TIME MEASURE																				
TIME BUILD OUT																				
LOCK																				
HOLDOVER	Ignore error information from TS1 and clock the time engine at a holdover frequency averaged by the evaluation software while the PLL was locked to an input signal.																			
AUTO FREQ LOCK	Fully automatic PLL operation with frequency-only locking. When the PLL is locked its output frequency tracks the frequency of the input signal, but time is not adjusted. Therefore the MAX24288 time engine will have a fixed time offset vs. the source of the input signal.																			
AUTO TIME LOCK	Fully automatic PLL operation with time-and-frequency locking. When the PLL is locked the time and frequency of the MAX24288 time engine track the input signal.																			
EVENTS PER SECOND	Specifies the number of edges per second in the input signal timestamped by TS1. For a 1PPS signal this field should be set to 1.																			
FREERUN FREQ PPM	Specifies a frequency offset vs. the frequency accuracy of the REFCLK oscillator for when PLL MODE above is set to FREERUN.																			
FREQ RATE OF CHANGE PPM/SEC	Specifies the maximum frequency rate of change that the evaluation software can use when locking to an input signal.																			
PLL BANDWIDTH, HZ	Specifies the bandwidth of the hardware/software PLL in Hz.																			
PLL DAMPING FACTOR	Specifies the damping factor of the hardware/software PLL. A typical value is 5. Larger numbers provide more damping, i.e. less peaking at the PLL corner frequency.																			

Table 18. TEST Menu

Name	Description
READ REGISTER	Function reads the register specified by the REGISTER ADDRESS fields below and displays the value in the REGISTER DATA fields below.
WRITE REGISTER	Functions writes the data value specified in the register data fields below into the register address specified by the REGISTER ADDRESS fields below.
REGISTER ACCESS MODE	Specifies the register access mode. MAX24288 USER MODE: The registers in Table 7-1 of the MAX24288 data sheet are at addresses 0-31 decimal, and the registers in Table 7-2 of the MAX24288 data sheet are at 32 (decimal) + SPI address. MAX24288 MDIO: The MAX24288 registers are addressed using the MDIO addresses in Tables 7-1 and 7-2 of the MAX24288 data sheet. The page number must be manually set by writing the PAGESEL register at address 31 decimal. To use this mode polling must be stopped by entering s on the command line. This prevents the polling routine from changing the MDIO page in the PAGESEL register. SW PHY0 (MDIO#8): Accesses the registers of PHY0 on the evaluation board's switch chip. SW PHY1 (MDIO#9): Accesses the registers of PHY1 on the evaluation board's switch chip. SW MAC (MDIO#A): Accesses the MAC registers of the evaluation board's switch chip for the port connected to the MAX24288. SFP CFG (I2C#A0): Accesses the SFP module's internal EEPROM memory. SFP PHY (I2C#AC): Accesses the SFP module's PHY registers.
REGISTER ADDRESS HEX	Specifies the register address in hexadecimal for the READ REGISTER and WRITE REGISTER functions above. When REGISTER ADDRESS DEC below is changed, this field is changed to match. The REGISTER ACCESS MODE field above specifies the register mapping.
REGISTER ADDRESS DEC	Specifies the register address in decimal for the READ REGISTER and WRITE REGISTER functions above. When REGISTER ADDRESS HEX above is changed, this field is changed to match.
REGISTER DATA HEX	Indicates the data value in hexadecimal from the last time the READ REGISTER function was executed or the last time one of the REGISTER DATA fields was change by the user.
REGISTER DATA DECIMAL	Indicates the data value in decimal from the last time the READ REGISTER function was executed or the last time one of the REGISTER DATA fields was change by the user.
READ SFP MODULE INFO	Functions reads and displays the data from the evaluation board's SFP module. To end the data display and return to the menu, press the ENTER key.

6. Jumpers, Connectors and LEDs

Table 19. Power and Reset Components

COMPONENT	LABEL AND TYPE	BASIC SETTING	SCHEMATIC PAGE	DESCRIPTION
J1	5V jack	Connected	4	Power jack for 5V wall adapter (supplied)
DS1 DS2 DS3	5.0V_OK LED 3.3V_OK LED 1.2V_OK LED	On	4	Lit when power is within range for 5V, 3.3V, and 1.2V, respectively
SW1	DUT_RST button	Unused	5	Manual reset for entire system

Table 20. MAX24288 REFCLK Jumpers and Connectors

Note: MAX24288 is intolerant of REFCLK signal changes during operation. To make REFCLK signal changes, power down the board, change the jumpers as needed then apply power to the board again.

COMPONENT	LABEL AND TYPE	BASIC SETTING	SCHEMATIC PAGE	DESCRIPTION
JP1	Y2OSC / Y3OSC selection 3-pin header	Jumper connecting pins 2 and 3	7	Drives SMB connector J3 and jumper J14 pin 1. Connect the Y3OSC pin to the center pin to connect the Y3 oscillator output to J3 and J14. Connect the Y2OSC pin to the center pin to connect the Y2 oscillator output to J2 and J14.
J3	OSC_OUT SMB connector	Not monitored	7	J3 is driven by a buffer sourced by the center pin of JP1.
J4	SER_TRM 2-pin header	Not monitored	7	Install a jumper on J4 to apply 50 ohm parallel termination to J3
J10	EXT_REFCLK SMB connector	Not monitored	7	External REFCLK oscillator input. Signal goes to J14 pin 1.
J25	50PAR 2-pin header	Not monitored	7	Jumper J25 to apply 50 ohm parallel termination to J10.
J14	REFCLK 2x3pin header	Jumper connecting pins 5 and 6	7	Connects 25MHz XO clock or Y2/Y3 clock or external clock to MAX24288 REFCLK pin. Frequency must match the settings of the REF[1:0] jumpers (see Table 21). Connect pins 1 and 2 to select the external clock signal from SMB J10. Connect pins 3 and 4 to select the Y2 or Y3 clock signal from JP1. Connect pins 5 and 6 to select the Y1 clock signal.
J19	OSC 3.3V POWER 2x3pin header	All jumpered	7	Connect/disconnect 3.3V power for oscillator components Y1, Y2 and Y3. Connect pins 1 and 2 to power Y3 Connect pins 3 and 4 to power Y2 Connect pins 5 and 6 to power Y1 Note: the silkscreen mistakenly has Y2OSC and Y3OSC labels swapped.

Table 21. MAX24288 Pin Configuration Jumpers

COMPONENT	LABEL AND TYPE	BASIC SETTING	SCHEMATIC PAGE	DESCRIPTION
JP13	HW_MODE 3-pin header	Jumper in the 15PIN position.	3	MAX24288 COL pin. At reset this pin specifies 3-pin or 15-pin configuration mode.

COMPONENT	LABEL AND TYPE	BASIC SETTING	SCHEMATIC PAGE	DESCRIPTION
JP15	TXCLK 3-pin header	Jumper in the GND position.	3	MAX24288 TXCLK pin. At reset the value on this pin is latched into the GMIICR.TXCLK_EN bit to configure TXCLK behavior. 0=high impedance. 1=125MHz from TX PLL. Ignored in MII mode.
JP16	AN_EN 3-pin header	Jumper in the GND position.	3	MAX24288 RX_DV pin. At reset the value on this pin is latched into the BMCR.AN_EN bit to configure auto-negotiation. 0=auto-negotiation disabled. 1=enabled.
JP17	DDR 3-pin header	Jumper in the GND position.	3	DDR: MAX24288 CRS pin.
JP29 JP30	SPEED[1:0] 3-pin header	JP29: VCC JP30: GND	3	SPEED[1:0]: MAX24288 RXD[1:0] pins. At reset the values on these pins are latched into the GMIICR.DDR and SPD[1:0] register bits. These jumpers together set the parallel interface mode for the MAX24288. See Table 22 for encodings. The equivalent interface configuration must be made on the Ethernet switch IC MODE and SPEED jumpers (see Table 27).
JP18	GPIO1_TX125 3-pin header	Jumper in the GND position.	3	MAX24288 GPO1 pin. At reset the value on this pin is latched into GPIOCR1.GPIO1_SEL[2] to configure GPIO1 behavior. 0=high impedance. 1=125MHz from TX PLL.
JP19	BASEX_DCE 3-pin header	Jumper in the GND position.	3	MAX24288 GPO2 pin. At reset the value on this pin is latched into GMIICR.DTE_DCE when SPEED[1:0] and DDR specify 10/100 MII mode or into PCSCR.BASEX when SPEED[1:0] and DDR specify some other mode. For 10/100 MII, 0=DCE, 1=DTE and the serial interface is configured for SGMII mode (PCSCR.BASEX=0). For other parallel interface modes, 0=SGMII, 1=BASEX.
JP14 JP23 JP24 JP25 JP26	ADDRESS[4:0] 3-pin headers	JP14: GND JP23: GND JP24: VCC JP25: GND JP26: GND	3	MAX24288 RX_ER and RXD[7:4] pins. At reset the values on these pins are latched into the internal MDIO PHY address register. Address 11111 enables factory test mode and should not be used. JP14 is RX_ER and ADDRESS[4]. JP23-JP26 are RXD[7:4] and ADDRESS[3:0].
JP27 JP28	REF[1:0] 3-pin headers	JP27: VCC JP28: GND	3	MAX24288 RXD[3:2] pins. At reset the values on these pins are latched into the internal REFCLK frequency register. 00=10MHz, 01=12.8MHz, 10=25MHz, 11=125MHz.
JP12	TX_ER 3-pin header	Jumper in the GND position.	3	MAX24288 TX_ERR pin.
TP1 TP2	TP1, TP2 Test points	Not used	1	Test points for TCLKN (TP1) and TCLKP (TP2)

COMPONENT	LABEL AND TYPE	BASIC SETTING	SCHEMATIC PAGE	DESCRIPTION
TX- TX+ RX+ RX- TP10	TX-, TX+, RX+, RX-, TP10 Test points	Not used	NA	Unconnected copper shapes have been placed next to each trace, and a section of the trace metal is exposed. A solder bridge may be used to bridge the trace to the shape, creating a test point.

Table 22. MAX24288 Parallel Interface Configuration

SPEED[1]	SPEED[0]	Speed	DDR=0	DDR=1
0	0	10Mbps	MII	RGMII-10
0	1	100Mbps	MII	RGMII-100
1	0	1000Mbps	GMII	RGMII-1000
1	1	reserved		

Table 23. MAX24288 GPIO1 Jumpers and Connectors

COMPONENT	LABEL AND TYPE	BASIC SETTING	SCHEMATIC PAGE	DESCRIPTION
J18	SMB Connector	Not jumpered	3	I/O connector for GPIO1.
JP5	GPIO1 3-pin header	Not jumpered	3	Can be used to bias GPIO1 high or low.
JP6 and JP9	3-pin headers	Not jumpered	3	To drive a signal from SMB J18 to GPIO1, jumper JP6 2-3 and JP9 2-3. To drive a signal from GPIO1 to SMB J18, jumper JP6 1-2 and JP9 1-2.
J22	2-pin header	Not jumpered	3	Install J22 to short the 30 ohm series termination at JP6.2.
J26	2-pin header	Not jumpered	3	Install J26 to apply 50 ohm parallel termination to JP9.2.
DS4	LED	Off	3	Lit when GPIO1 is high.

Table 24. MAX24288 GPIO2 Jumpers and Connectors

COMPONENT	LABEL AND TYPE	BASIC SETTING	SCHEMATIC PAGE	DESCRIPTION
J16	SMB Connector	Not jumpered	3	I/O connector for GPIO2.
JP4	GPIO1 3-pin header	Not jumpered	3	Can be used to bias GPIO2 high or low.
JP7 and JP10	3-pin headers	Not jumpered	3	To drive a signal from SMB J16 to GPIO2, jumper JP7 2-3 and JP10 2-3. To drive a signal from GPIO1 to SMB J16, jumper JP7 1-2 and JP10 1-2.
J23	2-pin header	Not jumpered	3	Install J23 to short the 30 ohm series termination at JP7.2.
J27	2-pin header	Not jumpered	3	Install J27 to apply 50 ohm parallel termination to JP10.2.

Table 25. MAX24288 GPIO3 Jumpers and Connectors

COMPONENT	LABEL AND TYPE	BASIC SETTING	SCHEMATIC PAGE	DESCRIPTION
J17	SMB Connector	Not jumpered	3	I/O connector for GPIO3.
JP3	GPIO1 3-pin header	Not jumpered	3	Can be used to bias GPIO3 high or low.
JP8 and JP11	3-pin headers	Not jumpered	3	To drive a signal from SMB J17 to GPIO3, jumper JP8 2-3 and JP11 2-3. To drive a signal from GPIO1 to SMB J17, jumper JP8 1-2 and JP11 1-2.
J24	2-pin header	Not jumpered	3	Install J24 to short the 30 ohm series termination at JP8.2.
J28	2-pin header	Not jumpered	3	Install J28 to apply 50 ohm parallel termination to JP11.2.

Table 26. Processor and Debug Jumpers and Connectors

COMPONENT	LABEL AND TYPE	BASIC SETTING	SCHEMATIC PAGE	DESCRIPTION
J2 (USB)	USB jack	Connected	8	USB connector, attach to PC with supplied cable
J5	PROCESSOR DEBUG 2x3pin header	Not Connected	8	BDM connector for use with debug pod
J9	COM_BCLK 2x3pin header	Not jumpered	5	Used to make a common communication clock. Jumper options allow to short MDC, I2C_CLK and SPI clock.
J12	2x5pin header	Jumpered 3-4, 5-6, 7-8, 9-10	5	Connection points for processor pins to SFP I2C and MAX24288 MDIO. Disconnect if connecting an external processor.
J13	2x5pin header	Jumpered 1-2, 3-4, 5-6, 7-8	5	Connection points for processor pins to MAX24288 SPI. Disconnect if connecting an external processor.
J15	2x7 header	Not used	5	Connection for external processor board
J21	2x5 header	Not used	5	SPI bus connection to external board such as Microsemi's DS31400DK.
J11	2-pin header	Not used	5	Place a jumper to connect 5V to J15 pin 2.
J34	2x5pin header	Jumpered 9-10	5	MAX24288 JTAG header. When not in JTAG mode the JTRST pin should be driven low by connecting pins 9 and 10.
JB1	2x5 header (just below the company logo)	Not jumpered	8	Connects to several GPIO on the processor to provide for future board application options.

Table 27. Ethernet Switch Jumpers, Connectors and LEDs

COMPONENT	LABEL AND TYPE	BASIC SETTING	SCHEMATIC PAGE	DESCRIPTION
JP2	SWITCH OSC 3-pin header	Jumper in the 25MHZ position.	7	Selects clock signal applied to the RTL8363 switch XTAL1 pin. Connect center pin to 25MHZ pin to select the clock signal from Y1. Connect center pin to EXT_SOSC to select the clock signal from SMB J7.
J7	EXT_SOSC SMB connector	Not Driven	7	External clock for Ethernet switch IC. JP2 must have jumper in the EXT_SOSC position to use this signal.
J8	50PAR 2-pin header	Not jumpered	7	Install jumper to apply 50 ohm parallel termination to the signal on J7.
JP20 JP21	SPEED[1:0] 3-pin headers	JP20: GND JP21: VCC	11	Switch IC P2SPD[1:0] pins. Selects speed of MII interface to MAX24288. The equivalent interface configuration must be made on the MAX24288 SPEED jumpers (see Table 21). 00: 10M 01: 100M 10: 1000M

COMPONENT	LABEL AND TYPE	BASIC SETTING	SCHEMATIC PAGE	DESCRIPTION
JP22 JP33 JP32	MODE[2:0] 3-pin headers	JP22: GND JP33: GND JP32: GND	11	Switch IC P2IF[2:0] pins. Selects mode of MII interface to MAX24288. The equivalent interface configuration must be made on the MAX24288 DDR and BASEX_DCE jumpers (see Table 21). 000: GMII/PHY MODE MII 001: GMII/MAC MODE MII 010: RGMII 011: RMII (do not use, not compatible with MAX24288)
JP31	RXDLY 3-pin header	Jumper in the VCC position.	11	Switch IC RXDLY pin, adds delay to RX CLK between MAX24288 and switch IC. Jumper to VCC to add 1.5nsec delay Jumper to GND to add 0 delay
JP34	TXDLY 3-pin header	Jumper in the VCC position.	11	Switch IC TXDLY pin, adds delay to TX CLK between MAX24288 and switch IC. Jumper to VCC to add 1.5nsec delay Jumper to GND to add 0 delay
J29	PORT1 RJ-45 jack	Not Connected	10	Interface to Port 1 of Ethernet Switch IC
J31	PORT0 RJ-45 jack	Connected	10	Interface to Port 0 of Ethernet Switch IC
DS14	DUP / COL LED	--	10	Port 1 status LEDs, indicate link status and speed.
DS13	10_LINK/ACT LED	--	10	
DS12	100_LINK/ACT LED	--	10	
DS11	GIG_LIN/ACT LED	--	10	
DS8	DUP / COL LED	--	10	Port 0 status LEDs, indicate link status and speed.
DS7	10_LINK/ACT LED	--	10	
DS6	100_LINK/ACT LED	--	10	
DS5	GIG_LIN/ACT LED	--	10	

Table 28. SFP Module Jumpers and LEDs

COMPONENT	LABEL AND TYPE	BASIC SETTING	SCHEMATIC PAGE	DESCRIPTION
J30	2x5pin header	Jumpered 8-6 Jumpered 4-3	6	SFP test points and bias points Default option 8-6 enables TX. Default option 4-3 connects SFP_LOS signal to MAX24288 ALOS pin.
DS9	TX_FAULT LED	--	6	Indicates SFP module transmit fault signal is active.
DS10	LOS LED	--	6	Indicates SFP module LOS signal is active.

7. Component List

DESIGNATION	QTY	DESCRIPTION	SUPPLIER	PART
Reference designators shown on next row (C1, ..., CB143)	81	0402 CERAM 1uF 10V	TDK	C1005X5R1A105M
C1, C2, C12, C13, C14, C22, C27, CB8, CB10, CB13, CB14, CB21, CB23, CB25, CB28, CB30, CB31, CB34, CB35, CB36, CB37, CB38, CB39, CB40, CB41, CB42, CB45, CB49, CB50, CB51, CB52, CB53, CB54, CB55, CB57, CB58, CB62, CB64, CB66, CB67, CB69, CB70, CB71, CB73, CB74, CB76, CB77, CB79, CB81, CB84, CB86, CB87, CB89, CB91, CB92, CB94, CB95, CB98, CB99, CB100, CB102, CB104, CB106, CB107, CB113, CB115, CB116, CB119, CB121, CB122, CB123, CB124, CB127, CB128, CB129, CB133, CB134, CB135, CB141, CB142, CB143				
Reference designators shown on next row (C3, ..., CB145)	41	0402 CERAM 0.01uF 16V 10%	Panasonic	ECJ-0EB1C103K
C3, C8, C10, C17, C24, CB3, CB7, CB12, CB26, CB27, CB47, CB59, CB60, CB61, CB63, CB65, CB68, CB72, CB75, CB78, CB80, CB82, CB83, CB85, CB88, CB90, CB93, CB96, CB97, CB101, CB103, CB105, CB108, CB109, CB110, CB111, CB114, CB117, CB118, CB120, CB145				
C4, C9, C11, C15, C16, C18, C19, C20, C21, C23, C25, C26, CB1, CB2, CB4, CB5, CB9, CB11, CB15, CB19, CB20, CB24, CB29, CB32, CB33, CB44, CB46, CB56, CB112, CB125, CB130, CB131, CB132, CB139, CB140, CB146	36	0603 CERAM 10uF 6.3V 20% MULTILAYER	Panasonic	ECJ-1VB0J106M
C5, CB18	2	0603 CERAM .1uF 16V 20% X7R	AVX	0603YC104MAT
C6, C7	2	0603 CERAM 22pF 25V 5% NPO	AVX	06033A220JAT
CB17, CB22	2	0603 CERAM 4.7uF 6.3V MULTILAYER	UNK	ECJ-1VB0J475M
CB43, CB48, CB126, CB136, CB137, CB138	6	CAP CER 3.3UF 4.0V X5R 0402	AMK	AMK105BJ335MV-F
CB6, CB16, CB144	3	D CASE TANT 470uF 6.3V 20%	KEM	T491D477M006AS
DB1	1	SCHOTTKY DIODE, 1 AMP 40 VOLT	International Rectifier	10BQ040
DS1, DS2, DS3, DS5, DS6, DS7, DS8, DS11, DS12, DS13, DS14	11	LED, GREEN, SMD	Panasonic	LN1351C
DS4, DS15, DS16	3	LED, GREEN, SMD	Panasonic	LN1351C
DS9, DS10	2	LED, RED, SMD	Panasonic	LN1251C
GND_TP1, GND_TP2, GND_TP3, GND_TP4	4	STANDARD GROUND CLIP	KEYSTONE	4954
J1	1	2.0MM SURFACE MOUNT POWER JACK	CUI INC	PJ-002AH-SMT
J11	1	2 PIN HEADER, .100 CENTERS, VERTICAL	Samtec	TSW-102-07-T-S
J12, J13, J30, J34	4	TERMINAL STRIP, 10 PIN, DUAL ROW, VERT	DIG	S2012-05-ND
J15	1	HEADER, 14 PIN, DUAL ROW, VERT NOT POPULATED	Samtec	HDR-TSW-107-14-T-D
J2	1	TYPE B SINGLE RT ANGLE, BLACK	MOL	NA
J29, J31	2	CONNECTOR, SINGLE LEVEL, GIGABIT RJ-45, 10 PIN WITH LED	Halo Electronics	HFJ11_1G41E_L12RL
J3, J7, J10, J16, J17, J18	6	CONNECTOR, SMB, 50 OHM VERTICAL, 5PIN	AMP	413990-1
J4, J8, J22, J23, J24, J25, J26, J27, J28, J32, J33	11	100 MIL 2 POS JUMPER	NA	NA
J5, J6, J9, J14, J19	5	TERMINAL STRIP, 6 PIN, DUAL ROW, VERT	Samtec	TSW-103-07-T-D
JB1 J15, J21	3	TERMINAL STRIP, 10 PIN, DUAL ROW, VERT DO NOT POPULATE	DNP	DNP

DESIGNATION	QTY	DESCRIPTION	SUPPLIER	PART
JP1, JP2, JP3, JP4, JP5, JP6, JP7, JP8, JP9, JP10, JP11, JP12, JP13, JP14, JP15, JP16, JP17, JP18, JP19, JP20, JP21, JP22, JP23, JP24, JP25, JP26, JP27, JP28, JP29, JP30, JP31, JP32, JP33, JP34	34	100 MIL 3 POS JUMPER	NA	NA
LB1, LB3, LB4, LB9, LB10, LB11, LB12, LB13, LB14	9	FERRITE 3A 100 OHM AT 100 MHZ 1206 SMD	Steward	HI1206N101R-00
LB5, LB6, LB7, LB8	4	1uH ±10% 0805 Multilayer Ceramic 400 mA (ok to sub with 445-3156-1-ND)	Murata	LQM21FN1R0N00D
R1, R4, R5, R6, R7, R9, R10, RB5	9	RES 0603 30 Ohm 1/16W	Panasonic	ERJ-3GEYJ300V
R11, R18, R19, R21, R57, RB8, RB3	4	RES 0402 0 OHM 1/10W 5%	Panasonic	ERJ-2GE0R00X
R12, R17, R20, R22, R23, R29, R31, R32, R33, R34, R35, R36, R37, R38, R39, R40, R41, R42, R43, R44, R45, R46, R47, R48, R49, R50, R51, R52, R53, R54, R55, R56	32	RES 0201 30.0 OHM 1/16W 1%	Panasonic	ERJ-1GEJ300C
R13, R14, R25, R26, RB23, RB24, RB25, RB38, RB44, RB45, RB49, RB50, RB51, RB52, RB53, RB54, RB56, RB57, RB63, RB64, RB69, RB71, RB72, RB73, RB77, RB78, RB79, RB80, RB81, RB86, RB87,	31	RES 0402 10.0 KOHM 1/16W 1%	Panasonic	ERJ-2RKF1002X
R16, RB27, RB28, RB29	4	RES 0402 30.0 OHM 1/16W 1%	Panasonic	ERJ-2RKF30R0X
R30, R15	2	RES 0402 100 OHM 1/16W 1%	Panasonic	ERJ-2RKF1000X
R2, R3	2	RES 0603 33.2 Ohm 1/16W 1%	Panasonic	ERJ-3EKF33R2V
R24, R28, R62, R63, RB13, RB15, RB16, RB17, RB18, RB19, RB20, RB21, RB22, RB26, RB39, RB40, RB41, RB42, RB43, RB82	18	RES 0402 1.00 KOHM 1/16W 1%	Panasonic	ERJ-2RKF1001X
R27	1	RES 0402 1.40 KOHM 1/16W 1%	Panasonic	ERJ-2RKF1401X
R8	1	RES 0603 1.00M Ohm 1/16W 1%	Panasonic	ERJ-3EKF1004V
RB1, RB4, RB9, RB30, RB31, RB32, RB33, RB34, RB60, RN1	11	RES 0603 1.0K Ohm 1/16W 5%	Panasonic	ERJ-3GEYJ102V
RB14, RB84, RB85, R60	5	RES 0603 330 Ohm 1/16W 5%	Panasonic	ERJ-3GEYJ331V
RB2, RB11, RB35, RB36, RB37	5	RES 0402 49.9 OHM 1/16W 1%	Panasonic	ERJ-2RKF49R9X
RB6, RB10, RB83	3	RES 0603 10K Ohm 1/16W 5%	Panasonic	ERJ-3GEYJ103V
RB65	1	RES 0603 2.49K Ohm 1/16W 1%	Panasonic	ERJ-3EKF2491V
RB7	1	RES 0603 10.0K Ohm 1/16W 1%	Panasonic	ERJ-3EKF1002V
RPB5, RPB6, RPB7, RPB9, RPB13	6	RESISTOR, 4 PACK, 330 OHM 5PCT QUAD 0603	Panasonic	EXB-V8V331JX
RPB10, RPB11	2	RESISTOR, 4 PACK, 10K OHM 5PCT QUAD 0603	Panasonic	EXB-V8V103JX
RPB2, RPB3, RPB4	3	RESISTOR, 4 PACK, 33 OHM 5PCT QUAD 0603	Panasonic	EXB-V8V330JV
RPB8, RPB12	2	RESISTOR, 4 PACK, 4.7K OHM 5PCT QUAD 0603	Panasonic	EXB-V8V472JX
SW1	1	SWITCH MOM 4PIN SINGLE POLE	Panasonic	EVQPAE04M
TP1, TP2, TP3, TP4, TP5, TP6, TP7, TP8, TP9, TP10, TP11, TP12, TP13, TP15, TP16, TP17, TPB1, TPB2, TPB3, TPB4, TPB5, TPB6, TPB7, TPB8, TPB9, TPB10	26	TESTPOINT, 1 PLATED HOLE, DO NOT STUFF	NA	NA
U1	1	MICROPROCESSOR VOLTAGE MONITOR, 3.08V RESET, 4PIN SOT143	Maxim	MAX811TEUS-T
U2	1	VOLTAGE MONITOR 5, 3.3, 2.5, ADJ	Maxim	MAX6709AUB+

DESIGNATION	QTY	DESCRIPTION	SUPPLIER	PART
UB3,UB4,UB5,UB6,UB9,UB10,UB11,UB12,UB13,UB14,UB15,UB16,UB19,UB20	14	HIGH SPEED BUFFER	FAIRCHILD	NC7SZ86
U4	1	IC, HCS08 8-BIT MICROCONTROLLER, 32K FLASH, 2K RAM, 2 UART, 2 SPI, I2C, USB, -40 TO 85C, 64 PIN LQFP	FREESCALE	MC9S08JM32CLH-ND
U5	1	RTL8363 PHY	REALTEK	RTL8363C
U6	1	MAX24288 QFN 8X8	MICROSEMI	MAX24288ETK+
U7	1	SFP host / receptacle	PARTS_KIT	SFP_HOST-TYCO
U8	1	IC, LINEAR REG ADJ, 2A, 14TSSOP-EP	MAXIM	MAX8526EUD+
UB2, UB7, UB17, UB18, UB21	5	IC, LINEAR REGULATOR, 1.5W, 3.3V OR ADJ, 1A, 16 PIN TSSOP-EP	Maxim	MAX1793EUE-33
XB1	1	XTAL, HC49SD, 12.0000MHz +/-50PPM, CL=20PF	FOX	FOXSDLF-120-20
Y1	1	OSCILLATOR LVCMOS, 3.3V, 25 MHZ, 4 PIN SMD	Connor-Winfield	MX010-025.0M
Y2	1	OSCILLATOR, VECTRON OCXO, 3.3V, 12.8 MHZ, 5 PIN THROUGH-HOLE	VEC	MC853X4-035W
Y3	1	OSCILLATOR, RAKON TC-OCXO, 3.3V, 10MHZ RFPO-30-RX-C-LF	RAKON	P5299LF
J9	1	TERMINAL STRIP, 6 PIN, DUAL ROW, VERT NOT POPULATED	Samtec	TSW-103-07-T-D NOT POPULATED
TP14	1	TESTPOINT, 1 PLATED HOLE RED	KEYSTONE	5000R
U3,UB1,UB8	3	TINYLOGIC HIGH SPEED 2-INPUT AND GATE, 5 PIN SOT23	Fairchild	NC7SZ08M5

8. Schematics

The MAX24288 EV Kit board design is a bill of materials modification of the MAX24287 EV Kit. See the following pages for the MAX24287 EV Kit schematics.

9. Ordering Information

PART	TYPE
MAX24288EVKIT	Evaluation Kit

10. Revision History

REVISION DATE	DESCRIPTION
10/11	Initial Release
2012-05	Reformatted for Microsemi. No content change.

MAX24287 EVKIT Rev_B

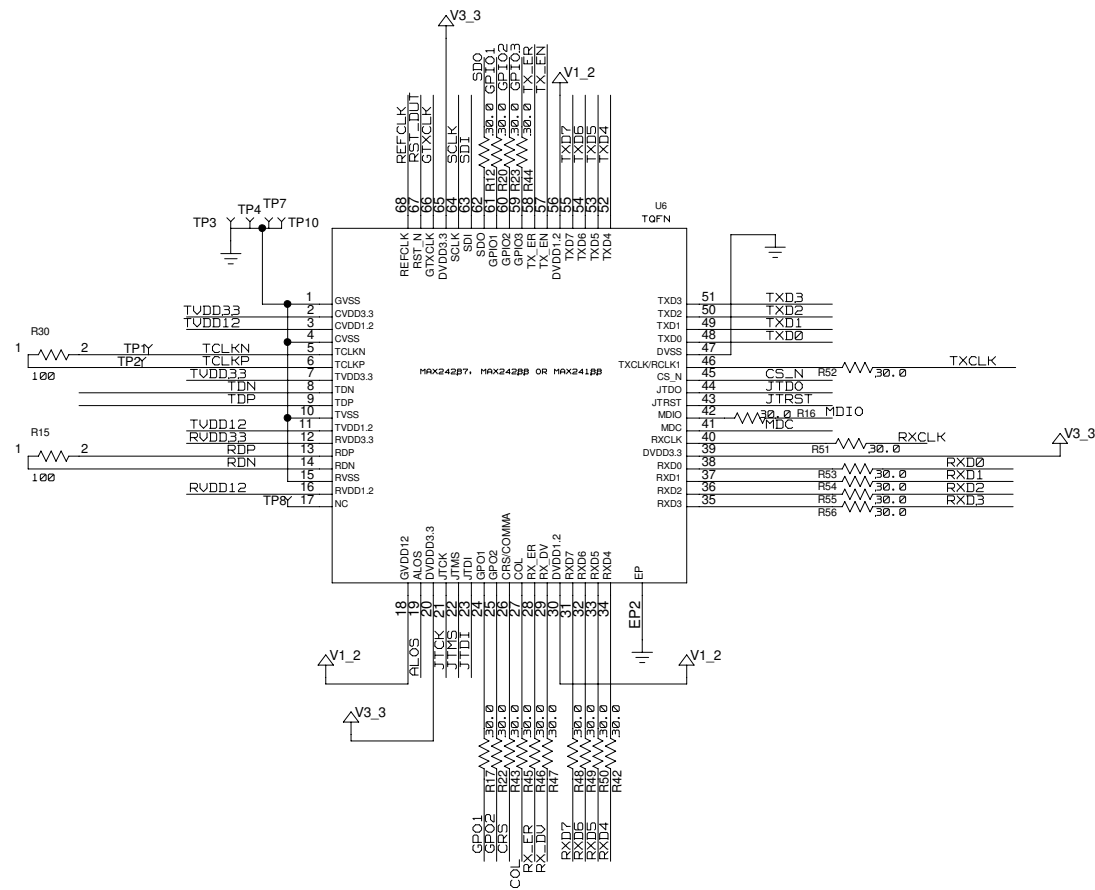

Top level Hierarchy block

TITLE: MAX24287 EVKIT Rev_B	DATE: 07-11-2011
ENGINEER: Steve Scully	PAGE: 1/1 (TOTAL) 1/B (BLOCK)

Switch Hierarchy block.
 Contents on page 9

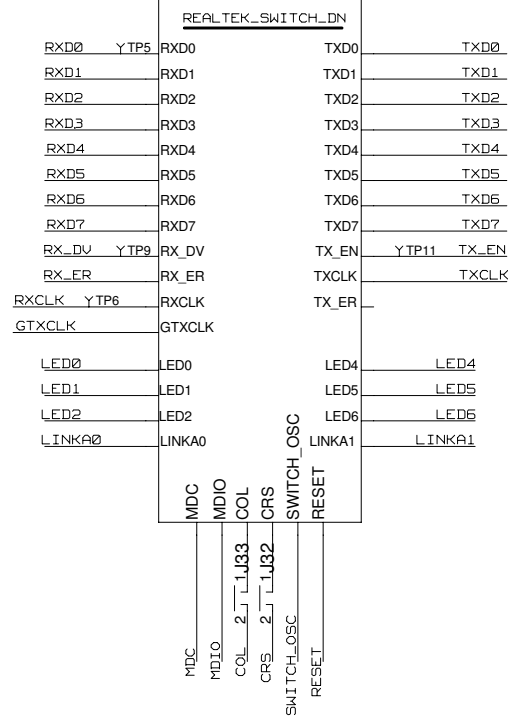

Top level Hierarchy block

TITLE:	MAX24287 EVKIT Rev_B	DATE:	07-11-2011
ENGINEER:	Steve Scully	PAGE:	2/11 (TOTAL) 2/B (BLOCK)

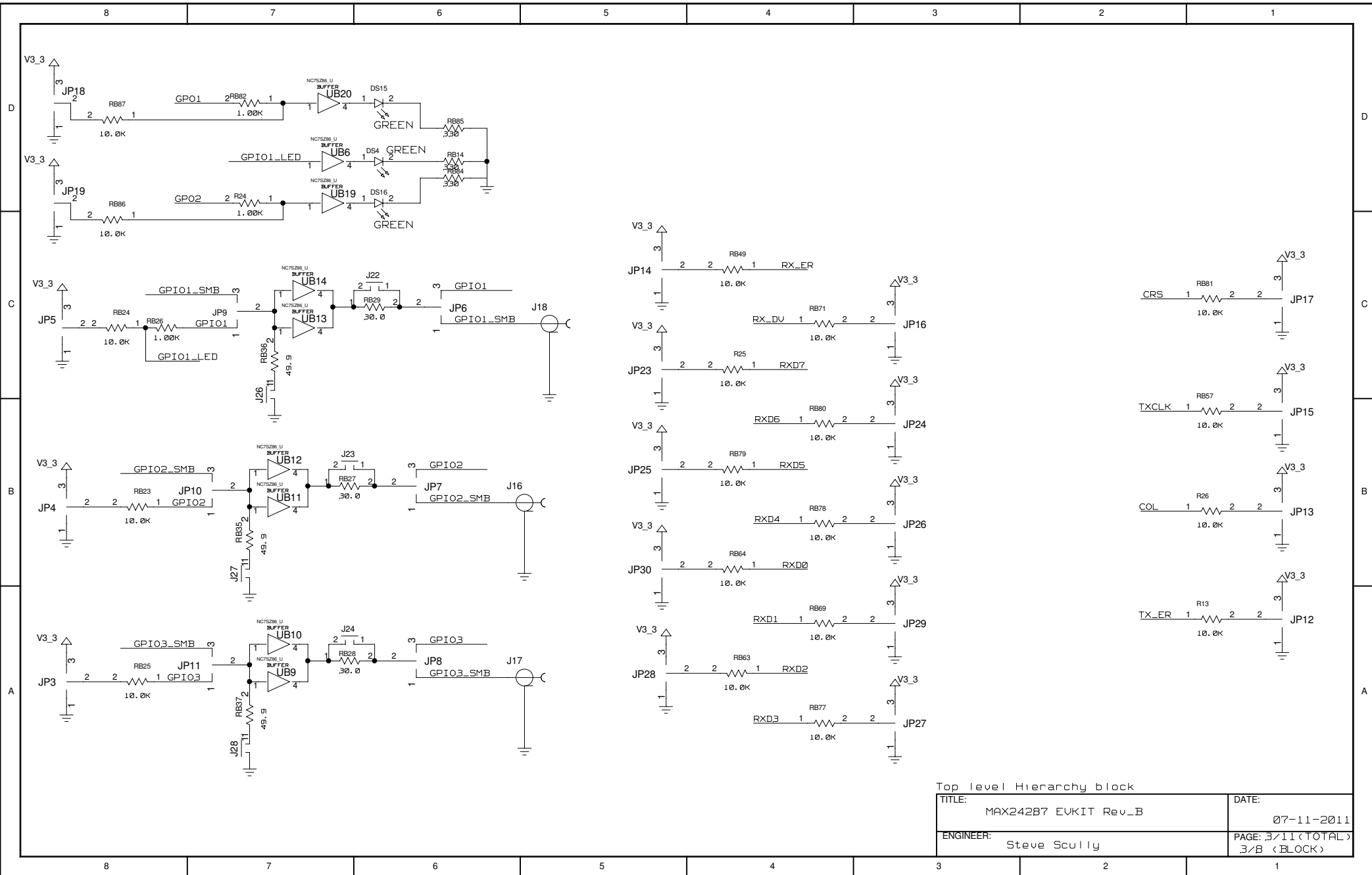

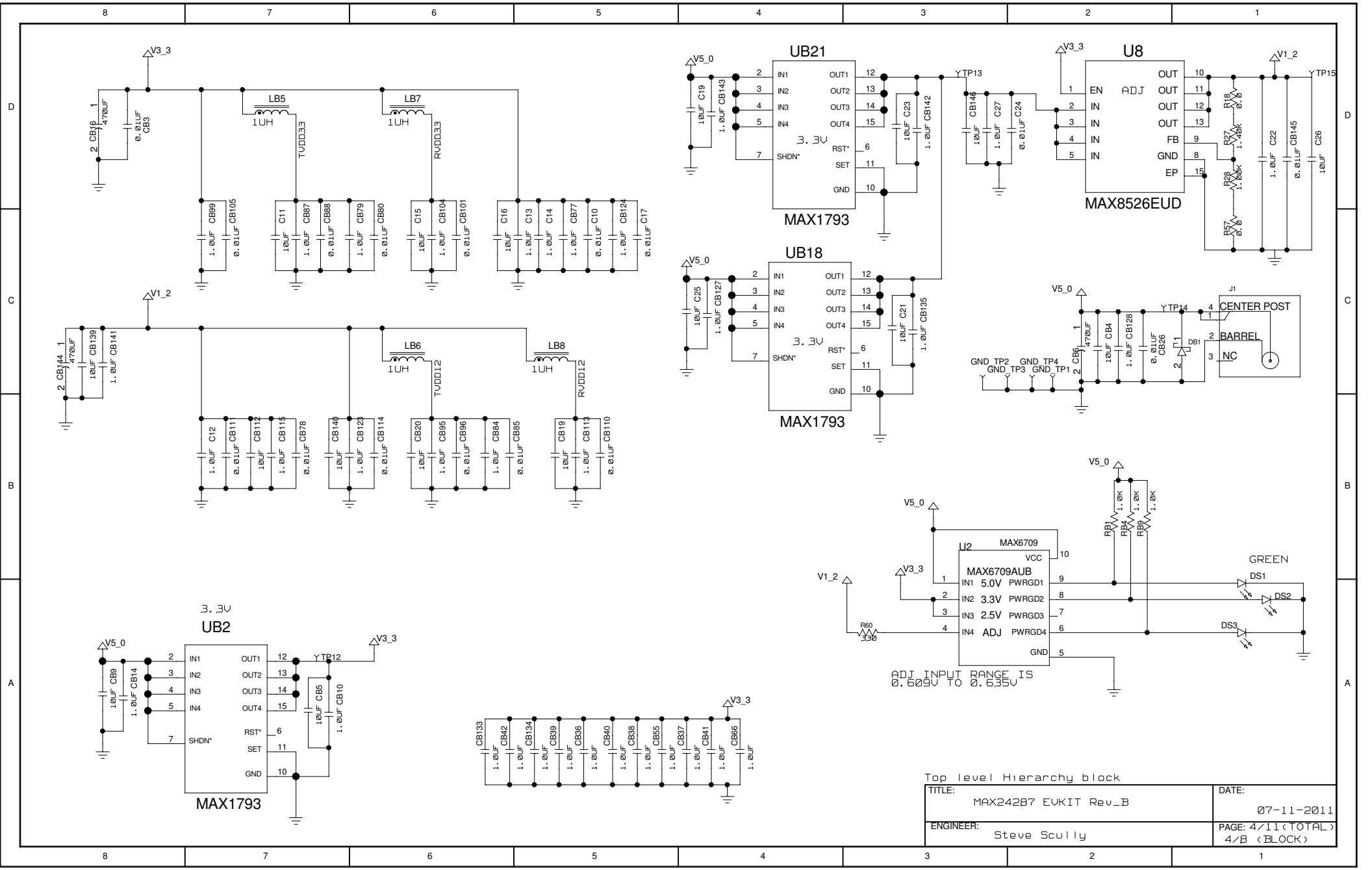

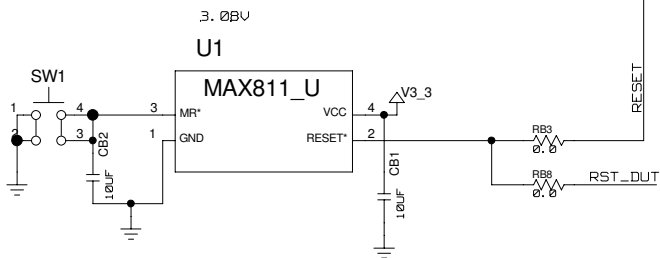
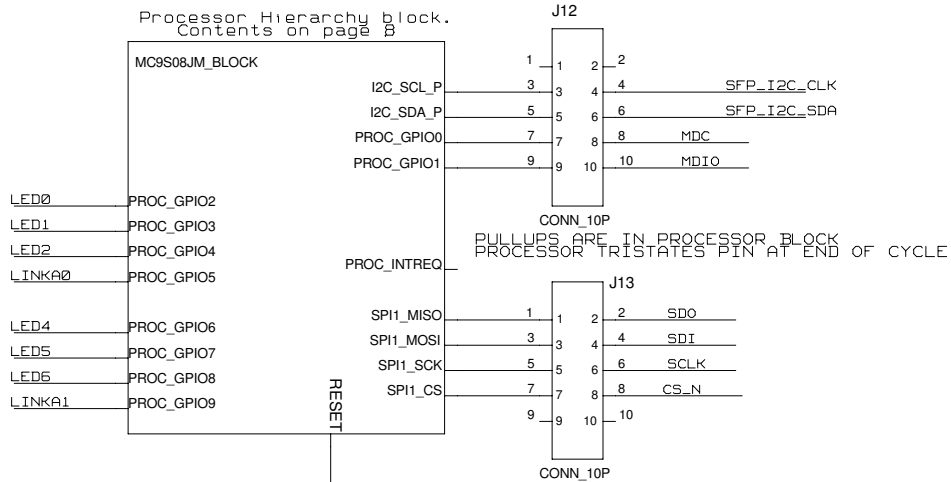
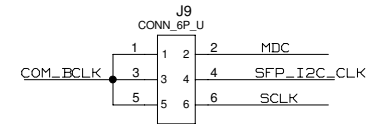
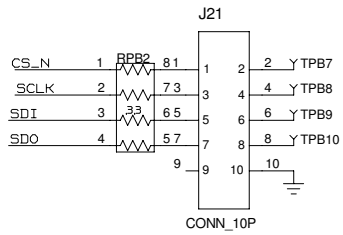
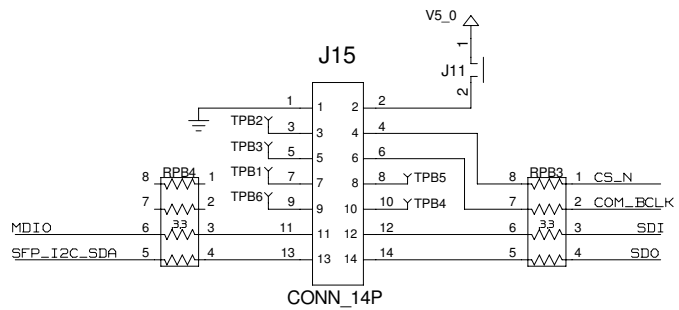

Top level Hierarchy block

TITLE: MAX24287 EVKIT Rev_B	DATE: 07-11-2011
ENGINEER: Steve Scully	PAGE: 5/11 (TOTAL) 5/B (BLOCK)

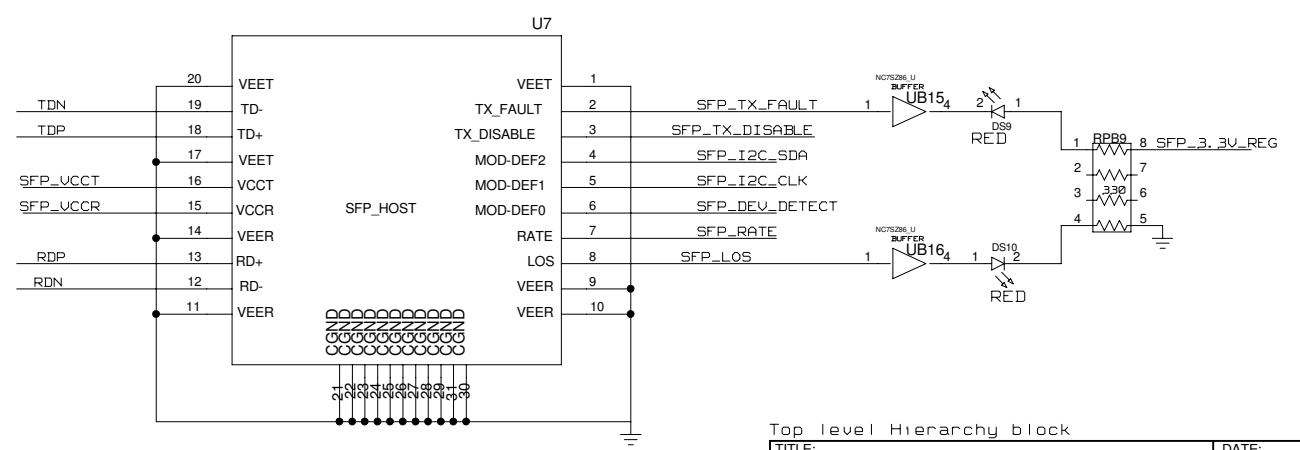
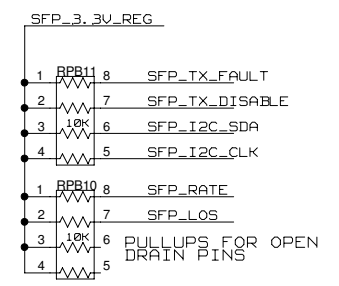
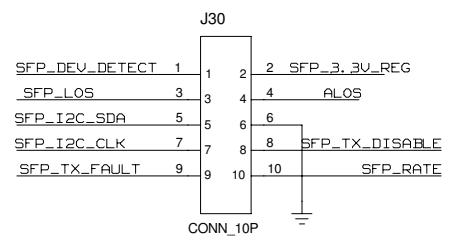
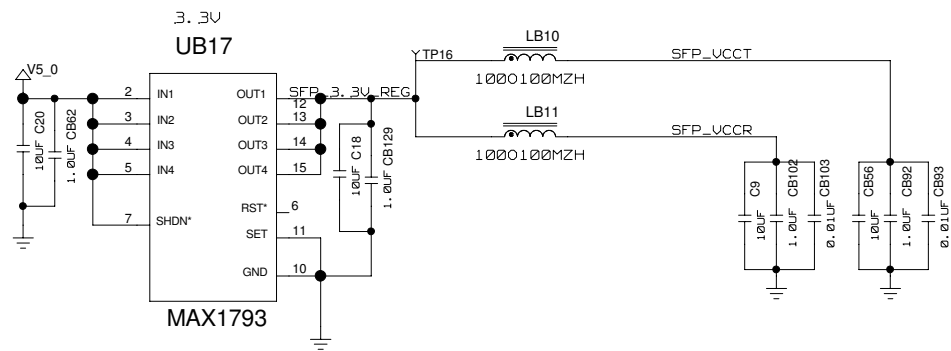

Top level Hierarchy block

TITLE: MAX242B7 EVKIT Rev_B	DATE: 07-11-2011
ENGINEER: Steve Scully	PAGE: 6/11 (TOTAL) 6/6 (BLOCK)

D

C

B

A

D

C

B

A

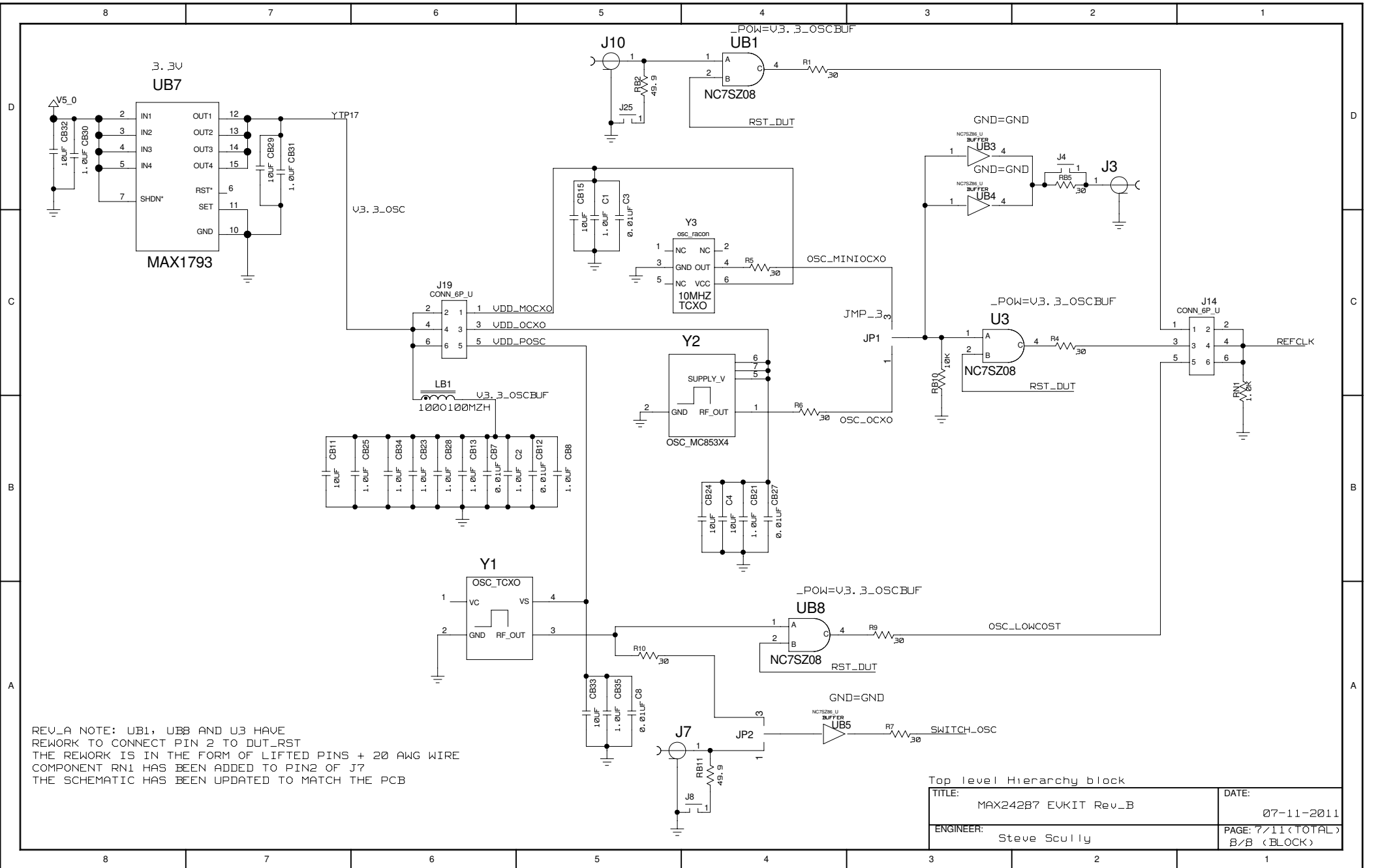

REV_A NOTE: UB1, UB8 AND U3 HAVE REWORK TO CONNECT PIN 2 TO DUT_RST THE REWORK IS IN THE FORM OF LIFTED PINS + 20 AWG WIRE COMPONENT RN1 HAS BEEN ADDED TO PIN2 OF J7 THE SCHEMATIC HAS BEEN UPDATED TO MATCH THE PCB

Top level Hierarchy block

TITLE: MAX2428B7 EVKIT Rev_B	DATE: 07-11-2011
ENGINEER: Steve Scully	PAGE: 7/11 (TOTAL) B/B (BLOCK)

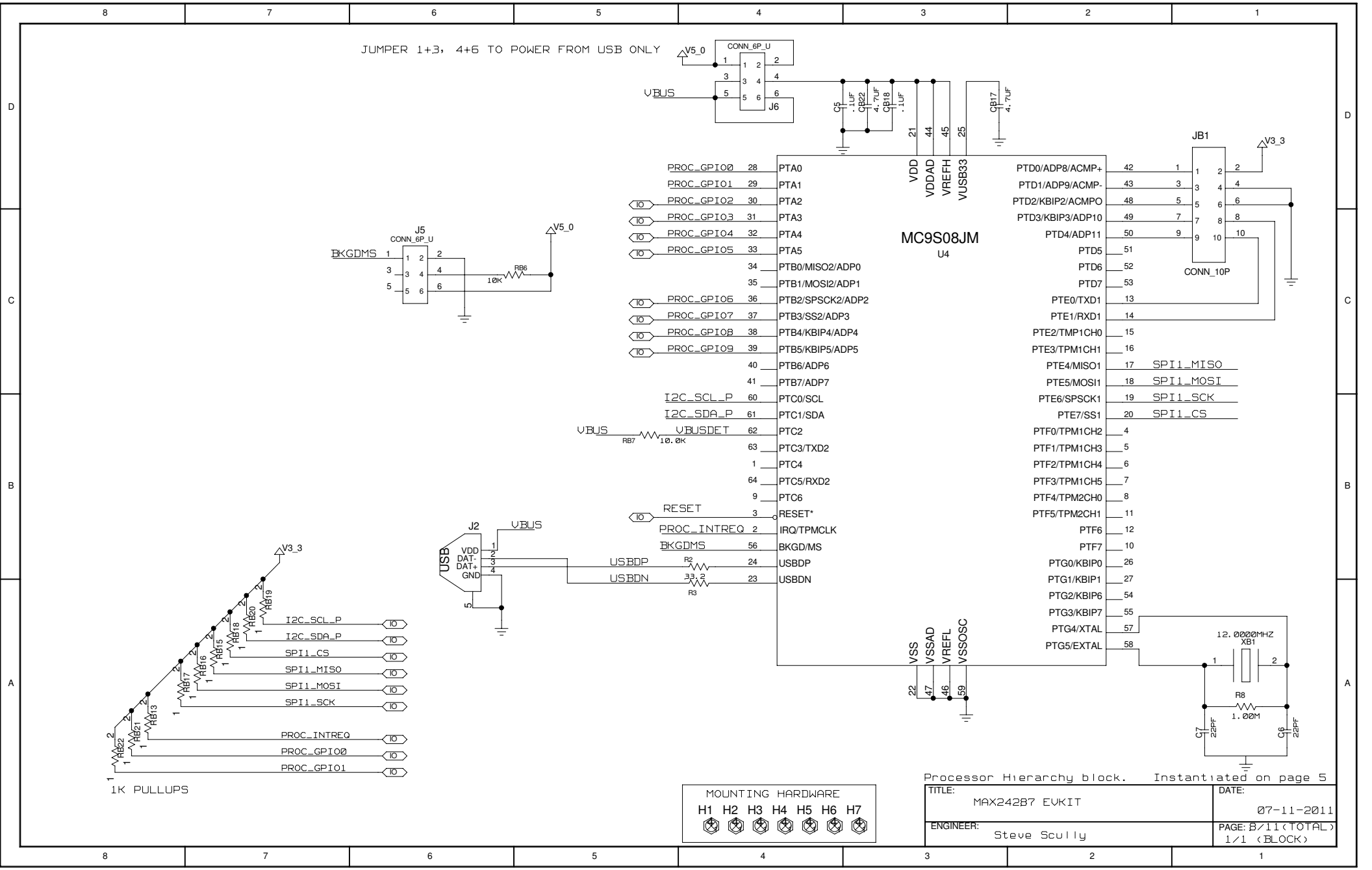

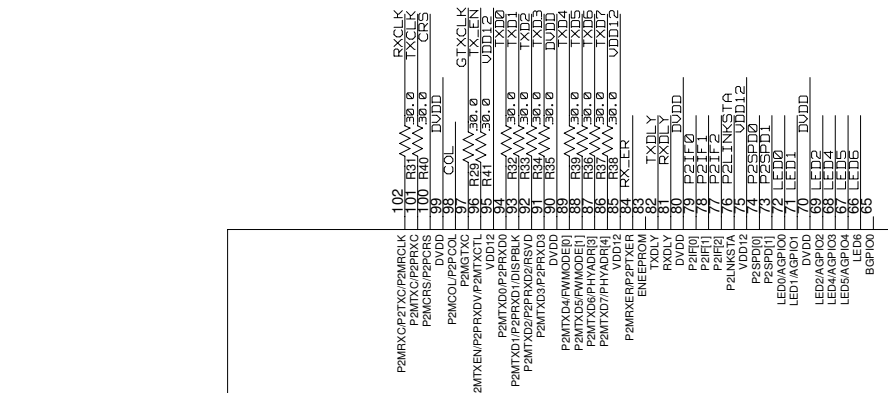

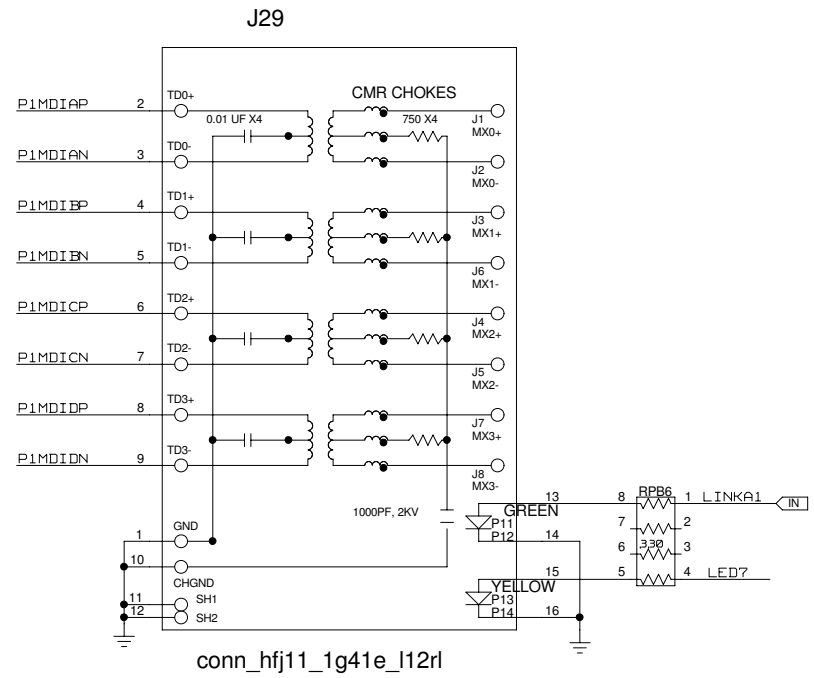
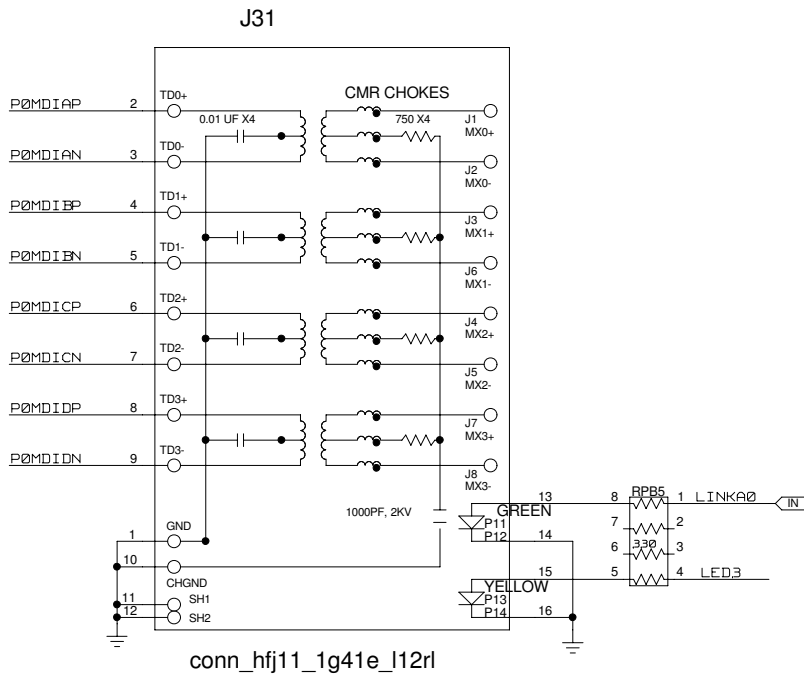

INDICATIONS FOR PARALLEL MODE0

- SWITCH0
- LED0=GIG-LINK/ACT
 - LED1=100-LINK/ACT
 - LED2=100-LINK/ACT
 - LED3=DUP/COL
- SWITCH1
- LED4=GIG-LINK/ACT
 - LED5=100-LINK/ACT
 - LED6=100-LINK/ACT
 - LED7=DUP/COL

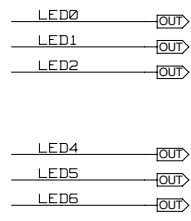
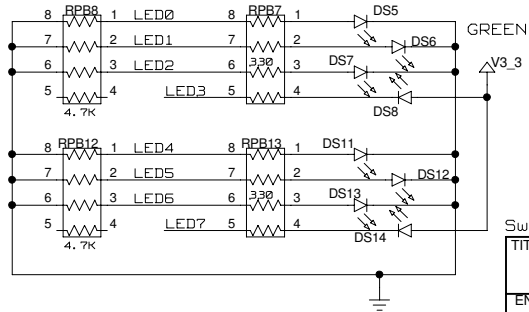

Switch Hierarchy block.

TITLE:	MAX24287 EVKIT	DATE:	07-11-2011
ENGINEER:	Steve Scully	PAGE:10/11 (TOTAL)	2/3 (BLOCK)

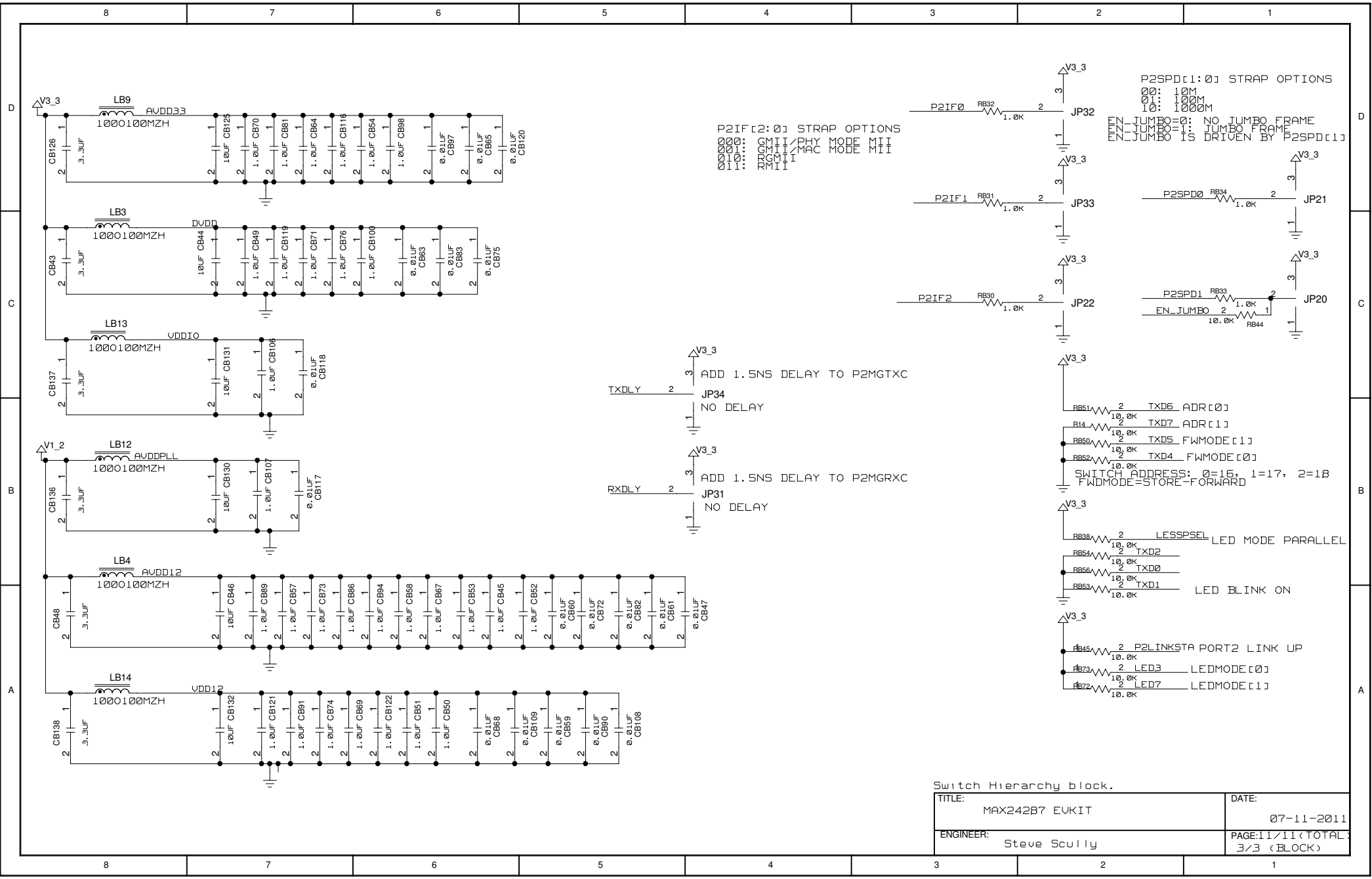

P2IF[2:0] STRAP OPTIONS
 000: GMII/PHY MODE MII
 001: GMII/MAC MODE MII
 010: RMII
 011: RMII

TXDLY 3 ADD 1.5NS DELAY TO P2MGTXC
 2 JP34
 1 NO DELAY

RXDLY 3 ADD 1.5NS DELAY TO P2MGRXC
 2 JP31
 1 NO DELAY

P2SPD[1:0] STRAP OPTIONS
 00: 10M
 01: 100M
 10: 1000M

EN_JUMBO=0: NO JUMBO FRAME
 EN_JUMBO=1: JUMBO FRAME
 EN_JUMBO IS DRIVEN BY P2SPD[1:0]

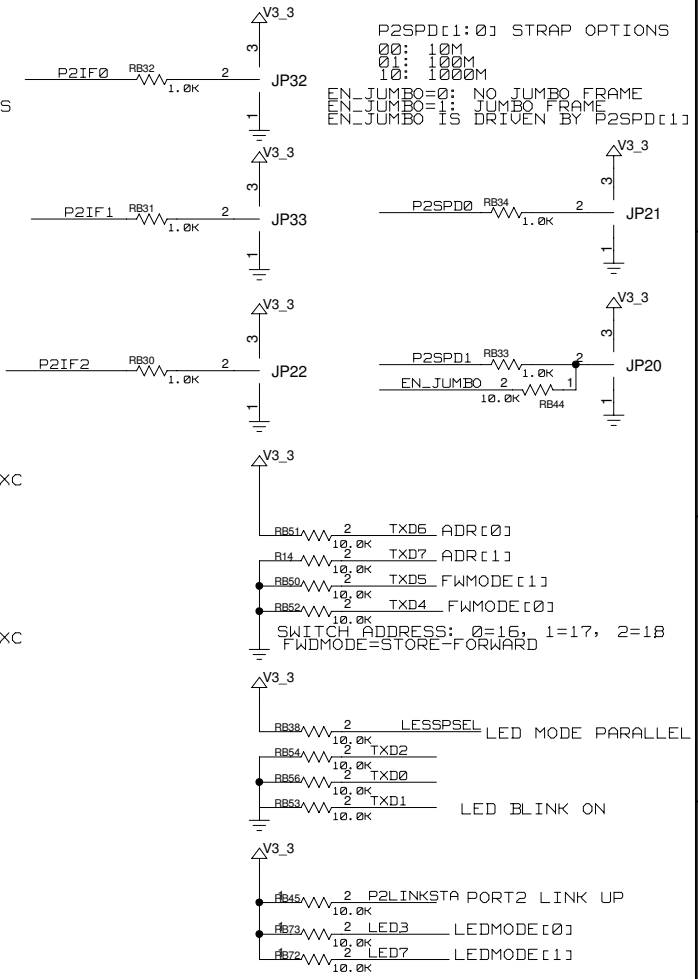

Switch Hierarchy block.

TITLE: MAX24287 EVKIT	DATE: 07-11-2011
ENGINEER: Steve Scully	PAGE:11/11(TOTAL) 3/3 (BLOCK)



Microsemi Corporate Headquarters
One Enterprise, Aliso Viejo CA 92656 USA
Within the USA: +1 (949) 380-6100
Sales: +1 (949) 380-6136
Fax: +1 (949) 215-4996

Microsemi Corporation (NASDAQ: MSCC) offers a comprehensive portfolio of semiconductor solutions for: aerospace, defense and security; enterprise and communications; and industrial and alternative energy markets. Products include high-performance, high-reliability analog and RF devices, mixed signal and RF integrated circuits, customizable SoCs, FPGAs, and complete subsystems. Microsemi is headquartered in Aliso Viejo, Calif. Learn more at www.microsemi.com.

© 2012 Microsemi Corporation. All rights reserved. Microsemi and the Microsemi logo are trademarks of Microsemi Corporation. All other trademarks and service marks are the property of their respective owners.