

NUMBER 66205

© 1963 BY AMP INCORPORATED. ALL RIGHTS RESERVED. AMP PRODUCTS COVERED BY PATENTS AND/OR PATENTS PENDING. APPROVED PER GOVT CONTRACT NO.

REVISIONS				
SYM	ZONE	DESCRIPTION	DATE	APPROVAL
A	#	REVISED U-625	2-3-4	M.S. <i>[Signature]</i>
B	#	REVISED V-636	11-16-4	M.S. <i>[Signature]</i>
B1		REVISED 2078 2055	4-1-69	M.S. <i>[Signature]</i>
C		LOC. 5 WAS AB, DIST. 12 WAS 39	ECN 9347	11-8-72 DS
D		ADDED 66211-6 TAPE MOUNTED	ECN 7420	4-10-73 GW
E		BRIGHT TIN .0001 WAS TIN .0002	EA 970	1-24-79 DWA
F		BRIGHT TIN-LEAD WAS BRIGHT TIN	EA 1818	6-18-81 DS
G		OBSOLETE 66205-3	ECNS2626	3-14-84 DS
H		OBSOLETE VARIOUS AM'S	ECN S3379	11-29-86 R.8
J		OBSOLETE 66210-3	ECN S3733	4-14-87 R.8
K		OBS 66208-2 PER ECN DF0357		5-26-88 CC
L		OBS 66209-4, 66210-2 ECN DF-0521	TW	9-26-88 <i>[Signature]</i>
M		SUPSD 66208 & 66211	CT	1-17-89 <i>[Signature]</i>

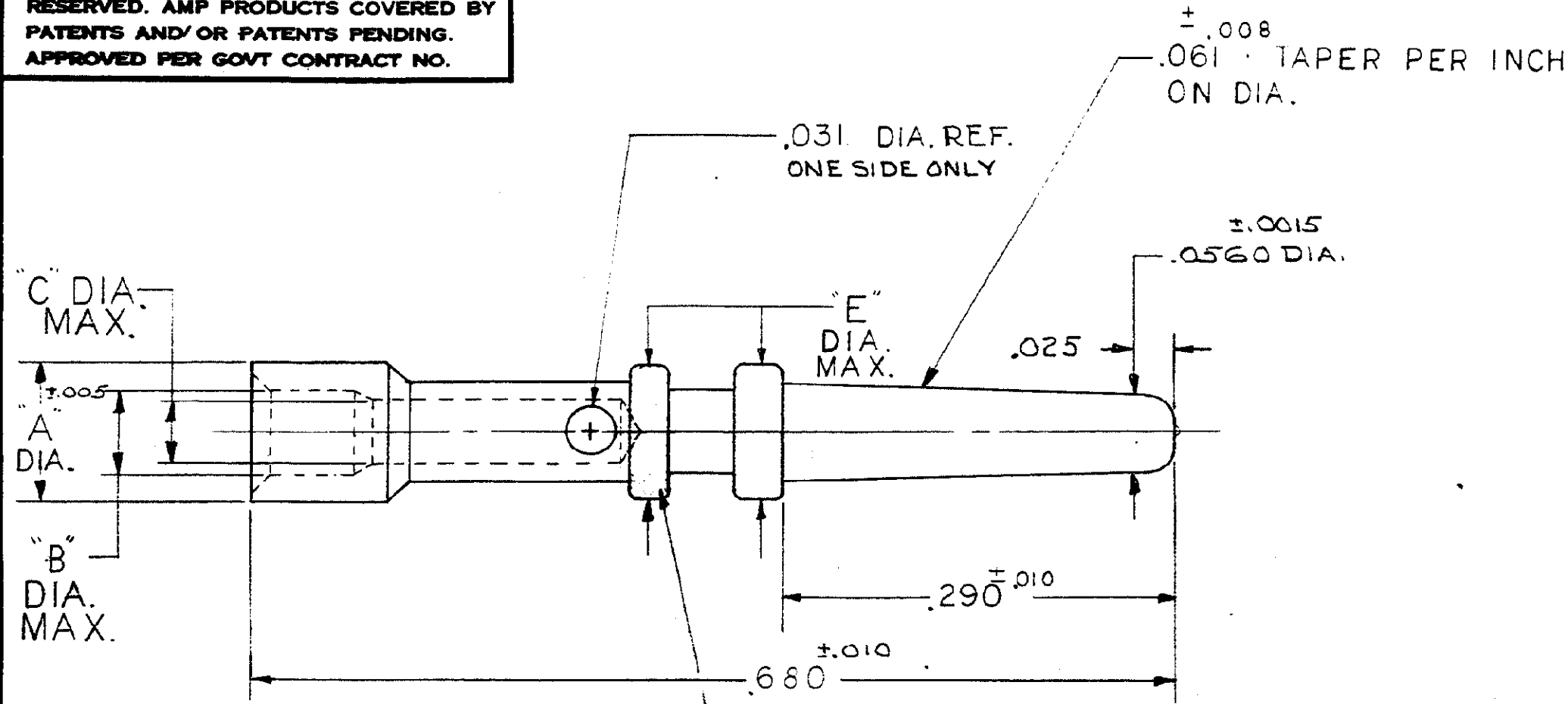

COLOR CODE SEE TABLE

TAPE NO.	PART NO.	A	B	C	E	FINISH	WIRE SIZE	INS. RANGE	COLOR CODE
	66211-4/S					BRIGHT TIN-LEAD			BLUE
	66211-3/S	.134	.110	.068	.135	SILVER	18 TO 16	.102 MAX.	BLUE
	66211-2					GOLD			
	66210-4/S					BRIGHT TIN-LEAD		.070	
	66210-3/S	.105	.091	.050	.100	SILVER		.083	
	66210-2					GOLD			
	66209-4/S					BRIGHT TIN-LEAD	24 TO 20	.055	YELLOW
	66209-3/S	.105	.082	.050	.100	SILVER		.070	
	66209-2					GOLD			
	66208-4/S					BRIGHT TIN-LEAD		.040	
	66208-3/S	.105	.068	.050	.100	SILVER		.058	
	66208-2					GOLD			
	66207-4/S					BRIGHT TIN-LEAD		.060	
	66207-3/S	.105	.086	.036	.100	SILVER		.078	
	66207-2					GOLD			
	66206-4/S					BRIGHT TIN-LEAD	28 TO 24	.045	RED
	66206-3/S	.105	.070	.036	.100	SILVER		.062	
	66206-2					GOLD			
	66205-4/S					BRIGHT TIN-LEAD		.031	
	66205-3/S	.105	.056	.036	.100	SILVER		.048	
	66205-2					GOLD			

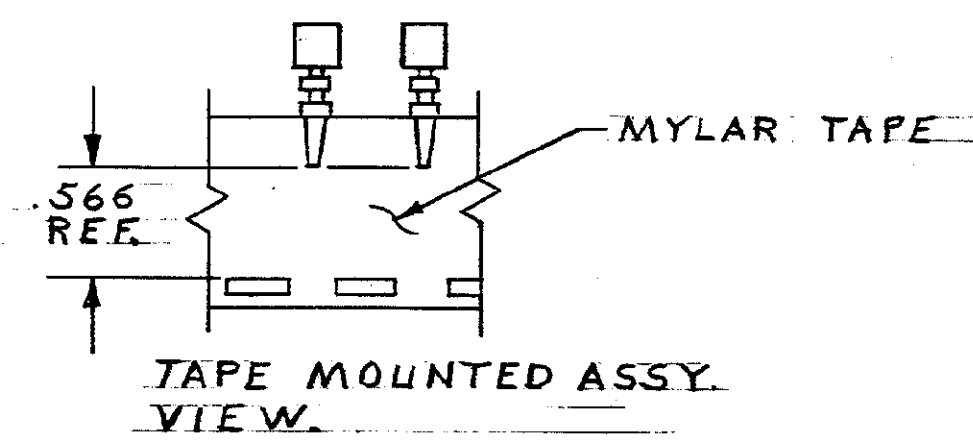

- ▲ BRIGHT TIN-LEAD .0001 THICK
- ▲ SILVER: .0002 THICK
- ▲ GOLD: .000030 GOLD OVER .000050 NICKEL
- ▲ OBSOLETE PART NUMBER.
- ▲ SUPSD & REDRAWN; SEE DWG 66208
- ▲ SUPSD & REDRAWN; SEE DWG 66211

AMP INFO		QTY REQD	NOMENCLATURE OR DESCRIPTION	PART OR IDENTIFYING NO		
M 3	LOC DF	DF	M			
LIST OF MATERIALS OR PARTS LIST						
UNLESS OTHERWISE SPECIFIED DIMENSIONS ARE IN INCHES TOLERANCES ON			SIGNATURE		DATE	
FRACTIONS DECIMALS ANGLES			OR <i>M. Smith</i>		11-18-3	
± 1/64 ± .015 ±			CHK <i>J. Kaufman</i>		11-19-63	
MATERIAL			DESIGN ENGR <i>M. Lora</i>		11-20-63	
HEAT TREAT			APPROV <i>[Signature]</i>		11-21-63	
FINISH			DESIGN APPD		CODE IDENT NO	
SEE TABLE			OTHER APPD		00779	
				SIZE	NUMBER	
				C	66205	
SCALE 10-1				WT	CALC	ACTUAL
					SHEET 1 OF 1	

CUSTOMER DRAWING