

THIS DRAWING IS UNPUBLISHED. RELEASED FOR PUBLICATION
 © COPYRIGHT BY TYCO ELECTRONICS CORPORATION. ALL INTERNATIONAL RIGHTS RESERVED.

LOC	DIST	REVISIONS			
P	LTR	DESCRIPTION	DATE	DWN	APVD
G	14	N	REV PER ECR 10-000722	25JAN10	JR TM

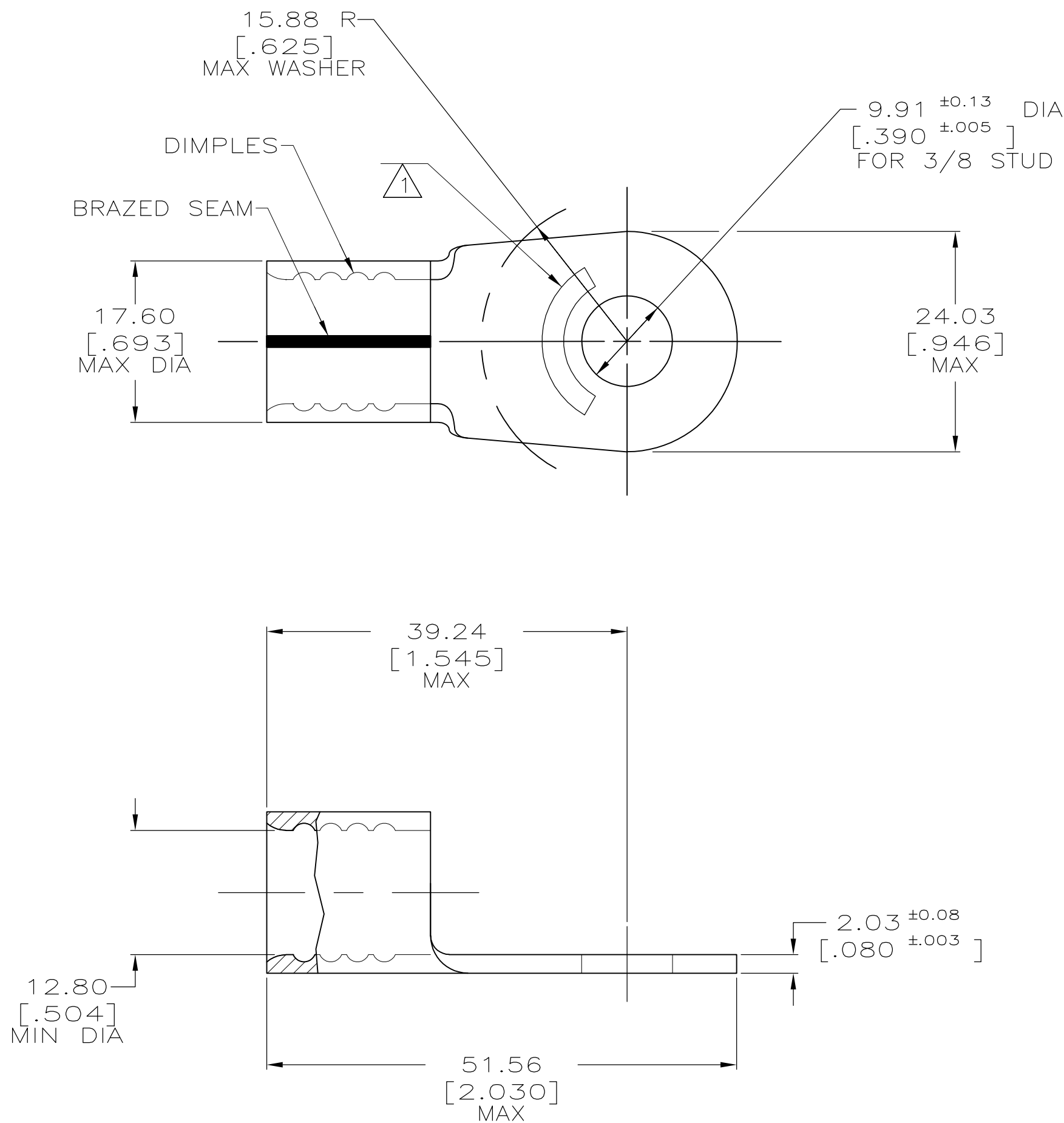

AMP WIRE RANGE	E13288 Listed	LR7189 Certified
2/0 AWG SOLID OR STRANDED	2/0 AWG STRANDED	2/0 AWG SOLID OR STRANDED

- 1 STAMP AMP 2/0W* APPROX AS SHOWN
- 2 COPPER PER ASTM B-152, ANNEALED
- 3 TIN PLATE 0.00254 [.000100] MIN THK EXT. PER ASTM B-545
- 4 MAX RECOMMENDED OPERATING TEMP IS 170°C.
- 5 WIRE CROSS SECTIONAL AREA RANGE: 60.6-76.3mm [119,500-150,500] CMA SOLID OR STRANDED.

25	SMALL PACK	8-36923-3
50	LOOSE PIECE	36923
QTY	PACKAGING TYPE	PART NO.

THIS DRAWING IS A CONTROLLED DOCUMENT.		DWN DK SCHRUM 1/14/94	Tyco Electronics Corporation Harrisburg, PA 17105-3608	
DIMENSIONS: MM [INCHES]		CHK AJ KAUFMAN 1/19/94		
TOLERANCES UNLESS OTHERWISE SPECIFIED:		APVD JL MECKLEY 1/19/94	NAME	
0 PLC ± -		PRODUCT SPEC	TERMINAL, RING TONGUE, SOLISTRAND	
1 PLC ± -		APPLICATION SPEC	SIZE CAGE CODE DRAWING NO RESTRICTED TO	
2 PLC ± 0.20[.008]		WEIGHT -	A2 00779 C=36923 -	
3 PLC ± -		CUSTOMER DRAWING	SCALE 2:1 SHEET 1 OF 1 REV N	
4 PLC ± -				
ANGLES ± -				
FINISH				

36923

A