

PART NUMBER	ITEM ① BODY	ITEM ② CRIMP SLEEVE
142-0003-241	BRASS GOLD PL .00001 MIN OVER NICKEL PL .00005 MIN OVER COPPER PL .00005 MIN	COPPER GOLD PL .00001 MIN OVER NICKEL PL .00005 MIN OVER COPPER PL .00005 MIN
142-0003-246	BRASS NICKEL PL .0001 MIN OVER COPPER PL .00005 MIN	COPPER NICKEL PL .0001 MIN OVER COPPER PL .00005 MIN

DRAWING NO. C - 142-0003-241/250	
0	REVISIONS
ENGINEERING RELEASE	
I	9-9-94 R H P K S ECN 42779

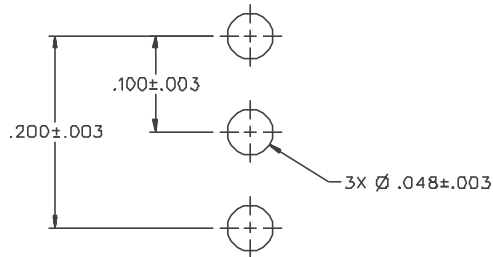

MOUNTING HOLE LAYOUT

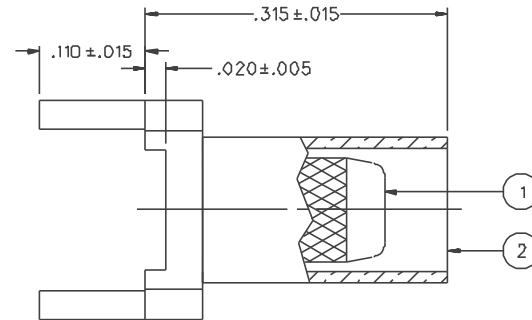
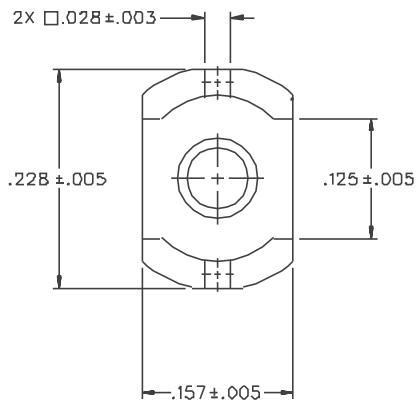
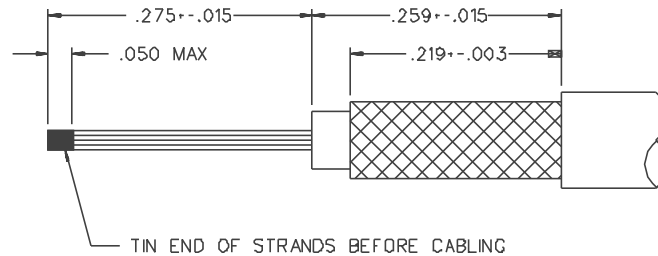

CABLE STRIP DIMENSIONS

CUSTOMER DRAWING

THIS DRAWING TO BE INTERPRETED
PER ANSI Y 14.5M - 1982

"μSTATION"

COMPANY CONFIDENTIAL

NOTES:

1. SPECIFICATIONS:

CABLE ACCEPTABILITY: RG 18B/U, RG 316/U, RG 161/U,
RG 174/U, RG 179/U, RG 187/U

CABLE HEX CRIMP SIZE: J28
CABLE RETENTION: 20 LBS.
IMPEDANCE: 50 OHMS

TOLERANCE UNLESS OTHERWISE SPECIFIED		DRAWN BY SWC	DATE 7-25-94	 Cinch Connectivity Solutions 299 Johnson Ave. Ste. 100 Worcester, MA 01609 1-800-247-8256
DECIMALS	mm	CHECKED BY	DATE	
.XX				TITLE CABLE TERMINATION, STRAIGHT PC MOUNT, RG 316
.XXX		APPROVED BY SWC	DATE 9-9-94	CODE NO.
MATL		APPROVED BY TAK/RJB	DATE 9-19-94	DRAWING NO. C - 142-0003-241/250
FINISH		RELEASE DATE		SCALE 10:1
				U/M INCH
				SHEET 2 OF 2